



KCO LN 60

Low noise
version

KCO LN Coanda effect low noise cassettes have been specially designed to merge harmoniously with the ceiling tiles and to be used for all types of applications such as offices, hotels, hospitals, etc.

Their diffusion grille (RAL 9016 colour), with a high induction rate, is specially designed in the concern to preserve the surrounding aesthetics and to favour the homogeneous diffusion of air in the room by the "COANDA" effect.



KCO LN 120

> General features <

Presentation

The KCO LN range is composed of **3 models** covering an air volume range from **120 to 700 m³/h** in order to meet the low sound level criteria.

The 3 models are :

- Model **KCO LN 60**. ceiling tile size of 600 x 600 mm
- Model **KCO LN 90**. ceiling tile size of 600 x 900 mm
- Model **KCO LN 120**. ceiling tile size of 600 x 1200 mm

Each model is available in several versions : **2 pipe, 2 pipe reversible, 2 pipe reversible with extra heating, 2 pipe/ 2 wire and 4 pipe versions.**

The KCO LN cassettes consist of **standard configuration without height extension** or **configuration with height extension** in order to allow the condensate flow by gravity and to avoid thus the addition of a condensate pump.

Casing

Made from 0.8 mm thick galvanized sheet steel with the fixing brackets located at the top part of the casing for installation to the ceiling. The casing is totally insulated by **a special acoustic insulation foam**, having M1 fire classification.

The access to internal components (fan-motor assembly and filter) for service and maintenance is facilitated by opening only the return grille.

PLAY® Diffusers

The KCO LN cassettes are equipped with **adjustable multidirectional (8 x 45°) PLAY® diffusers**.

The PLAY® diffusers allow a uniform air flow over a wide area with a COANDA effect, which leads to a high induction rate while reducing the stratification.

Their advantageous aesthetics allow to offer an innovative technical solution for architectural installations.

Coils

The coils are equipped with ISO-G 1/2" female tapped couplings, air vent and drain. All coils are leak tested under pressure of 30 bars in a water basin and are suitable for a maximum working pressure of 10 bars.

The condensate drain pan (made of 1.0 mm galvanized sheet steel) is coated with an epoxy painting. It is inclined to avoid water retention, removable and washable to satisfy high hygiene standards. The condensate drain pan is fitted with two 16 mm dia connection sleeves.

The whole coils and condensate drain pan is accessible from the side of the unit for all maintenance operations.

Fan-motor assembly

The fan-motor assembly consists of forward curved centrifugal double inlet type aluminium wheels, dynamically balanced.

The optimized conception of the fan-motor assembly confers a **low level of energy consumption** on the KCO LN cassettes : 53 Watts maxi. for the model KCO LN 60 and 105 Watts maxi. for the model KCO LN 120.

The direct drive motor has **6 speeds**, 3 speeds are pre-wired in factory, operates under nominal supply voltage of 230 V / 1 Ph / 50 Hz, and is fitted with an automatic reset internal thermal protection.

Air filter

The filter media, mounted on a rigid frame, is composed of cleanable synthetic fibre with high retention capacity, having a G3 classification (80 to 85 % gravimetric) complying with the requirements of the CEN EN 779 standard. The filter has a M1 fire classification.

For maintenance works, filter is accessible through the return grille.

Options and accessories

→ Electric heater for 2-pipe/2-wire system :

The in-tube type heating elements are directly inserted in the finned block. The safety actions are secured by **two safety thermostats** : one with **automatic reset** and another one with **manual reset**.

→ Fresh air intake :

The fresh air intake can be realized by using a pre-cut opening (Ø 100 mm or 125 mm) located on the side of the unit.

→ Regulation valves :

On/Off (thermal type actuator) 2 or 4 way valves for 2 or 4 pipe systems.

→ Height extension :

80 mm in height, this factory fitted accessory allows gravity condensate drainage.

→ Condensate pump :

The KCO LN cassettes can be fitted, as optional, with a condensate pump with 3 positions (on, off and alarm) ensuring optimization of pump operating times. With a maximum lift of 6 m, the pump guarantees a maximum flow rate of 6.8 l/h corresponding to a lift of 1 m. Its very low sound level, lower than 26 dBA, guarantees a perfect discretion for the best comfort of use.

Controls

Electromechanical, electronic, Aqu@Simp or Aqu@Net.



3 models

2-pipe, 2-pipe/2-wire or 4-pipe version

0.8 to 4.3 kW

1.1 to 6.4 kW

> General features (continued) <

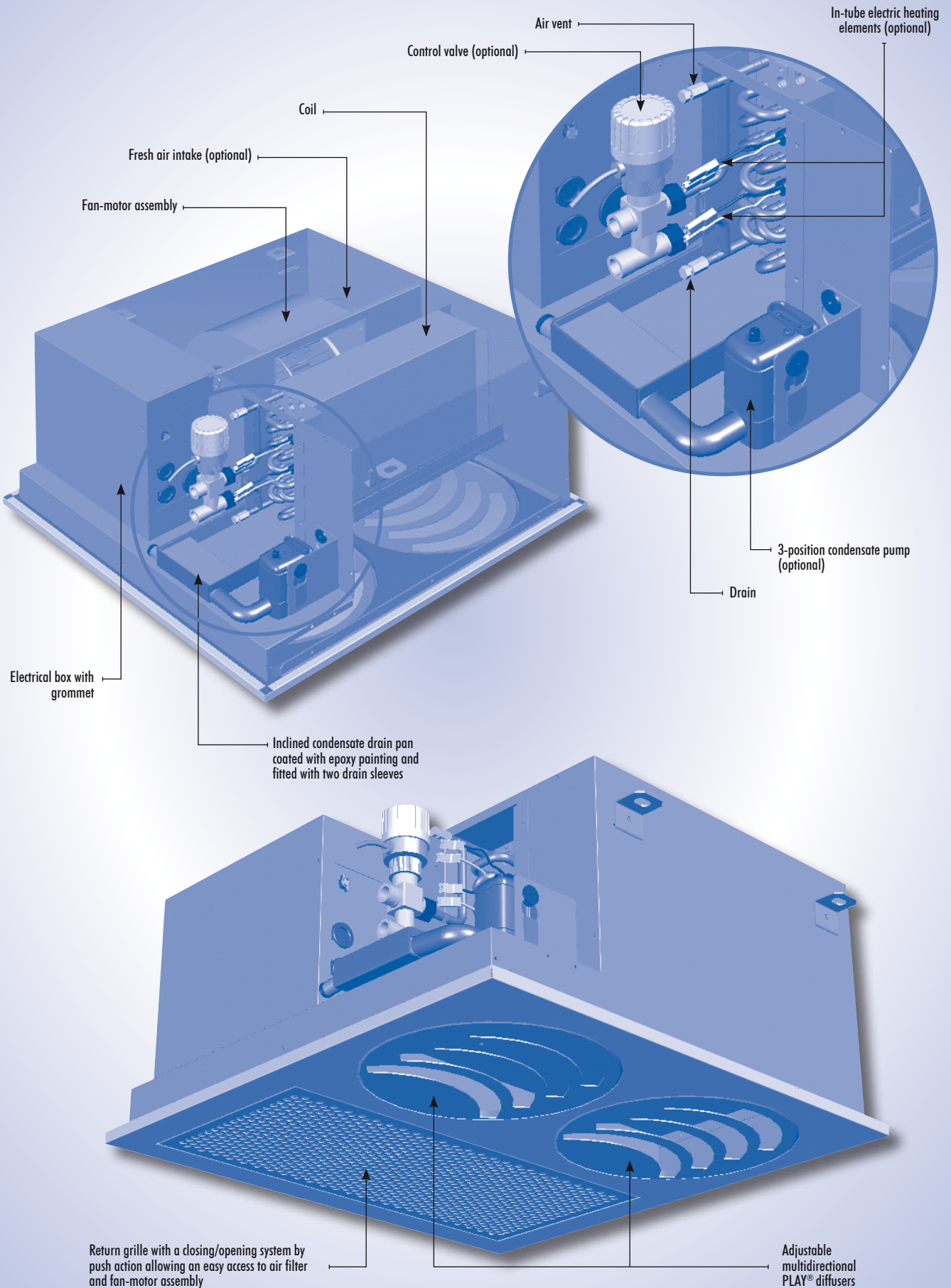

> Models <

KCO LN 60 Model

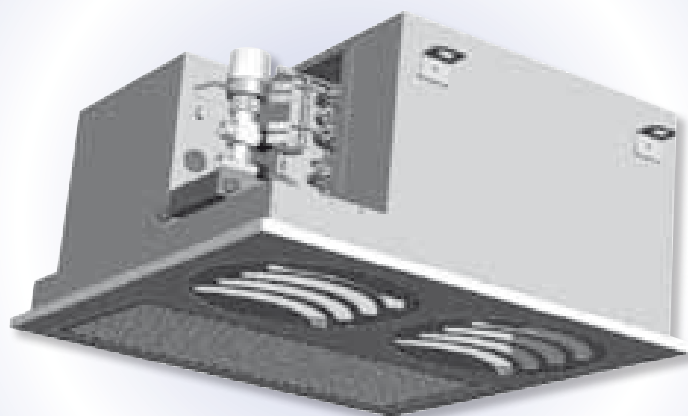

KCO LN 90 Model

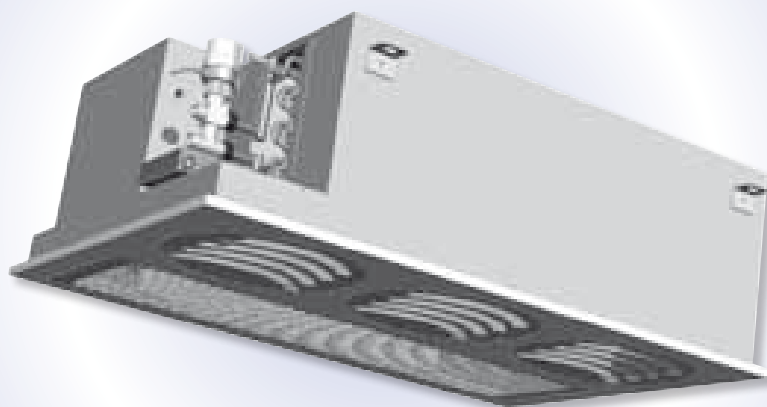

KCO LN 120 Model

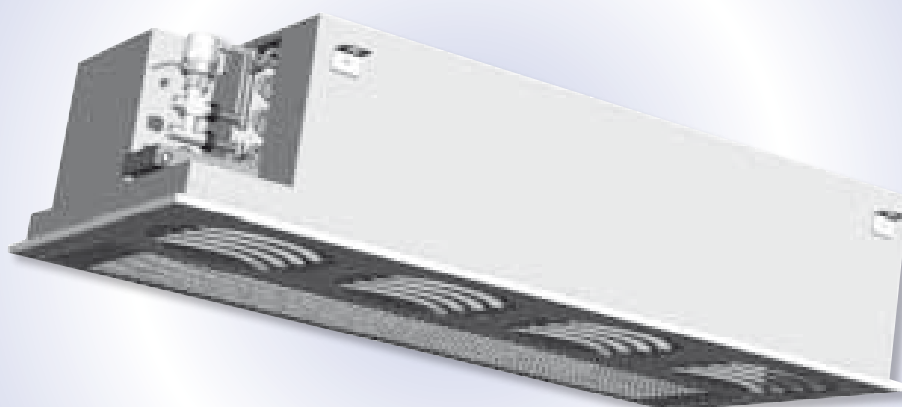



3 models

2-pipe, 2-pipe/2-wire or 4-pipe version



0.8 to 4.3 kW



1.1 to 6.4 kW

> Discharge air throw (in meters) <

Coanda effect

When air is blown from a point close to a ceiling, the air stream flattens itself against the ceiling and has a higher air throw.

The diffusion grille of the KCO LN cassette units uses this principle of air diffusion by the "Coanda effect", in order to ensure a homogeneous diffusion of air in the room with a high induction rate and a reduced temperature stratification.

Air throw

Air throw is the distance between the KCO LN unit and the points where the air velocity (0.2 m/s approx.) is no longer felt by the human body.

The tables below indicate the heating and cooling air throws of each KCO LN unit.

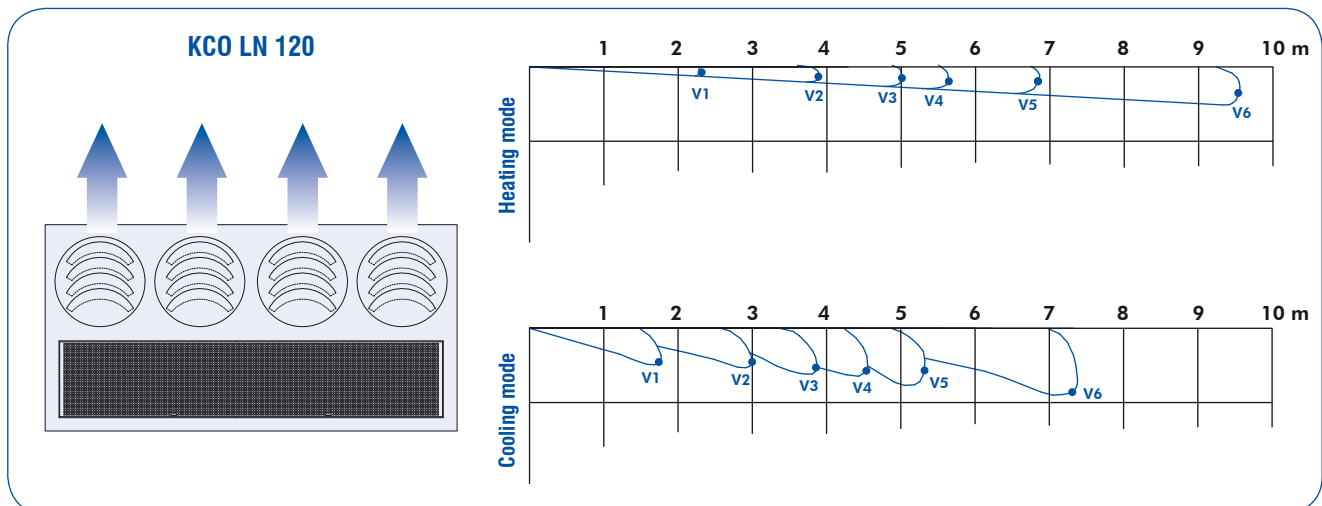
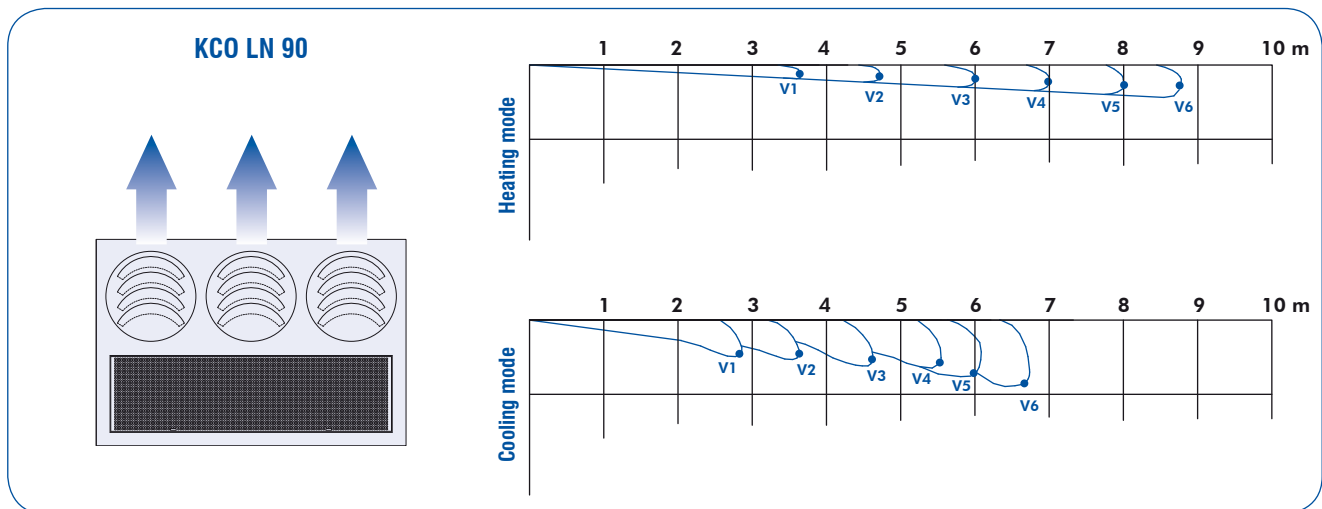
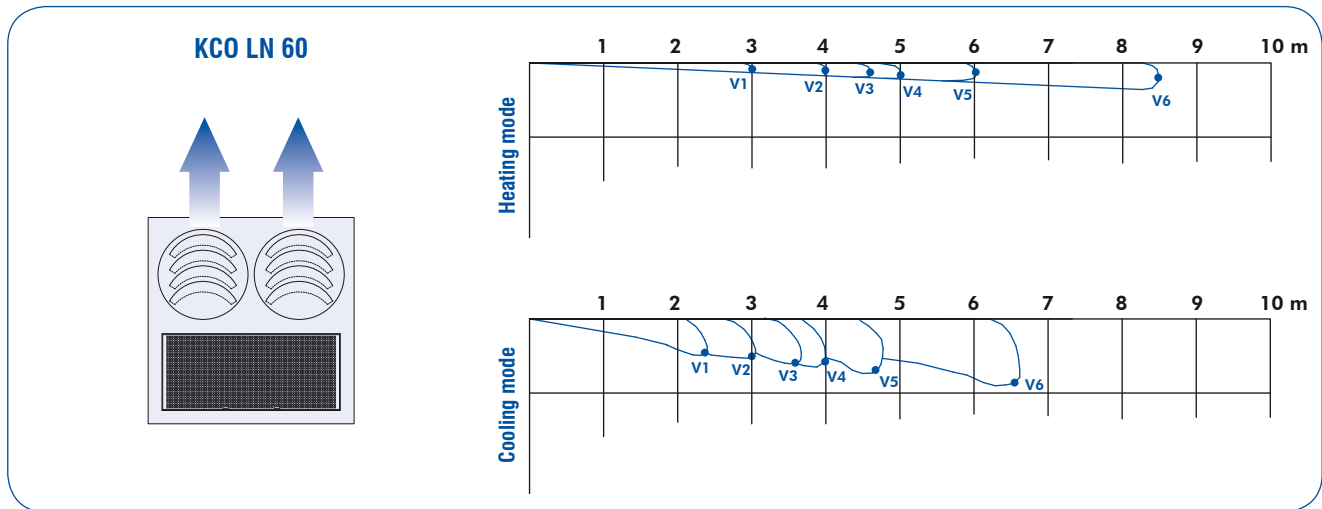

• : Point where air velocity of V1, V2, V3, V4, V5 and V6 is equal to 0.2 m/s.

> Definition of the service side <

The service side is determined by coil connection side when observer is looking at the unit from the discharge side.

LEFT-HAND service side

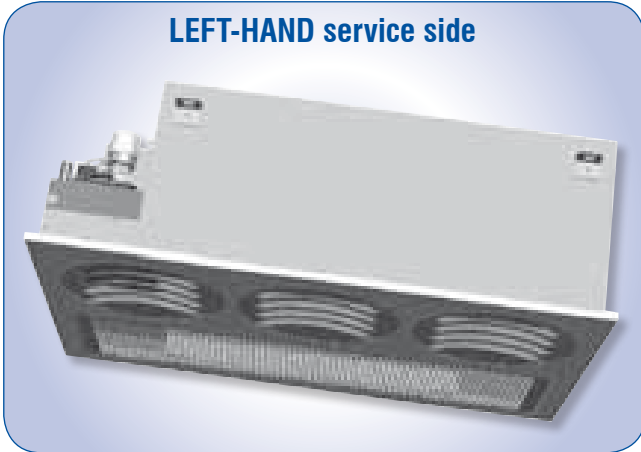

RIGHT-HAND service side



> Electric heater <

Models		KCO LN 60	KCO LN 90	KCO LN 120
Capacity (W)	BE1	400	1000	1500
	BE2	800	2000	2500
	BE3	1200	-	-

> Fan motor electrical data <

Models		KCO LN 60		KCO LN 90		KCO LN 120	
		Absorbed current (A)*	Absorbed power (W)*	Absorbed current (A)*	Absorbed power (W)*	Absorbed current (A)*	Absorbed power (W)*
Fan speed	V1	0.07	15	0.13	29	0.13	29
	V2	0.09	19	0.17	38	0.17	38
	V3	0.12	26	0.22	50	0.22	50
	V4	0.14	31	0.26	59	0.26	60
	V5	0.19	40	0.33	75	0.34	76
	V6	0.23	54	0.47	108	0.47	105

(*) Motor maximum absorbed current data given for operation with 230 V/1 Ph/50 Hz power supply and 0 Pa external static pressure.

> Coil water volume <

Models		KCO LN 60	KCO LN 90	KCO LN 120
Water volume (litres)	1 row	0.24	0.36	0.54
	3 rows	0.48	1.1	1.6

Notes :

- 2-pipe system is equipped with 3-row coil.
- 4-pipe system is equipped with 3+1 row coils.

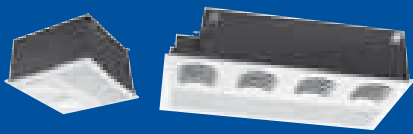

3 models

2-pipe, 2-pipe/2-wire or 4-pipe version



0.8 to 4.3 kW



1.1 to 6.4 kW

> Sound power levels Lw <

Model KCO LN 60

Speeds	Radiated Lw in dB(A)						Global dB(A)	(*) Lp dB(A)	NR
	125 Hz	250 Hz	500 Hz	1k Hz	2k Hz				
V1	19.2	25.5	25.7	25.2	23.0	31	26	21	
V2	23.2	30.0	29.9	34.4	24.2	38	32	28	
V3	26.4	34.7	34.5	35.2	26.7	41	35	31	
V4	29.3	35.9	42.1	36.2	31.3	45	39	36	
V5	33.1	39.8	43.2	40.5	36.0	50	45	41	
V6	38.7	45.4	51.1	48.7	43.8	55	49	46	

(*) The sound pressure levels are calculated according to the following conditions : 70 m³ room. 1 metre distance from the source and 0.5 s reverberation time.
Note : All sound power levels are given for the height extension configuration.

Model KCO LN 90

Speeds	Radiated Lw in dB(A)						Global dB(A)	(*) Lp dB(A)	NR
	125 Hz	250 Hz	500 Hz	1k Hz	2k Hz				
V1	22.1	27.3	26.6	18.7	19.2	37	32	29	
V2	28.7	35.7	37.0	35.5	30.7	43	38	32	
V3	32.8	39.9	41.7	41.4	36.5	47	41	36	
V4	35.8	42.5	44.8	45.0	41.0	51	45	40	
V5	39.5	45.1	48.4	48.7	45.3	54	48	44	
V6	43.2	49.3	52.1	53.2	49.5	58	53	48	

(*) The sound pressure levels are calculated according to the following conditions : 70 m³ room. 1 metre distance from the source and 0.5 s reverberation time.
Note : All sound power levels are given for the height extension configuration.

Model KCO LN 120

Speeds	Radiated Lw in dB(A)						Global dB(A)	(*) Lp dB(A)	NR
	125 Hz	250 Hz	500 Hz	1k Hz	2k Hz				
V1	16,3	23,8	29,5	29,7	24,8	33	28	25	
V2	25,2	31,3	32,7	32,0	31,5	38	33	27	
V3	29,8	36,2	38,7	38,4	36,2	43	39	34	
V4	33,2	38,3	41,7	43,5	40,5	48	43	38	
V5	36,7	43,2	46,4	47,6	43,3	53	48	43	
V6	43,3	49,2	52,4	54,0	51,1	58	53	49	

(*) The sound pressure levels are calculated according to the following conditions : 70 m³ room. 1 metre distance from the source and 0.5 s reverberation time.
Note : All sound power levels are given for the height extension configuration.

> Performance data - Standard models and models with height extension <

Models	Speeds	Air flow (m ³ /h)	Cooling capacity (W)		Heating capacity (W)	
			Total (1)	Sensible (1)	2-pipe system (2)	4-pipe system (3)
KCO LN 60	V1	117	800	600	1091	1497
	V2	144	963	729	1191	1659
	V3	177	1170	890	1530	1970
	V4	214	1316	1019	1665	2154
	V5	270	1432	1109	1837	2358
	V6	357	1740	1392	2277	2950
KCO LN 90	V1	210	1567	1021	1900	2389
	V2	270	1811	1218	2298	2930
	V3	338	2267	1525	2877	3462
	V4	390	2616	1760	3320	3824
	V5	460	2831	2085	3539	4323
	V6	550	3385	2493	4232	4898
KCO LN 120	V1	192	1613	1130	1846	2666
	V2	265	2005	1408	2469	3351
	V3	340	2384	1700	3027	3831
	V4	415	2900	2104	3683	4518
	V5	510	3534	2406	4488	5260
	V6	700	4340	3340	5511	6354

Notes :

- (1) Chilled water : 7/12 °C - Air : 27 °C/19 °C.
- (2) Hot water inlet : 50 °C - Cooling mode water flow rate - Air : 20 °C.
- (3) Hot water : 70/60 °C - Air : 20 °C.

> Water pressure drop - Cooling mode <

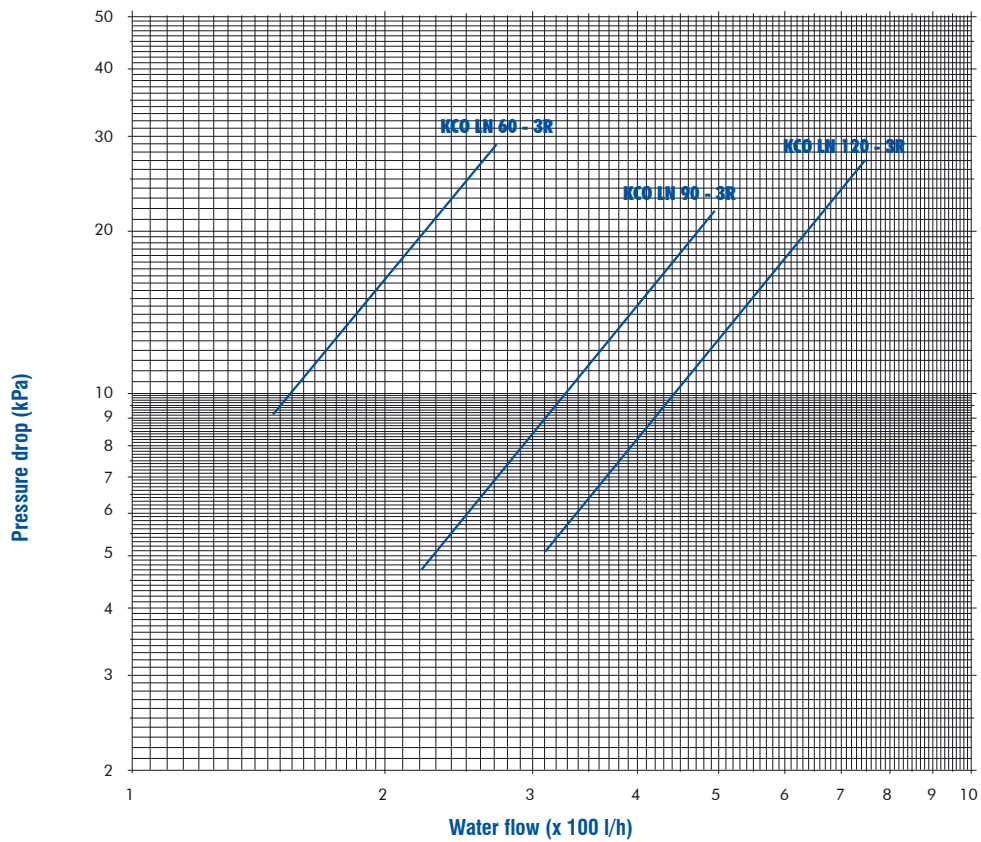

> Water pressure drop - Heating mode <

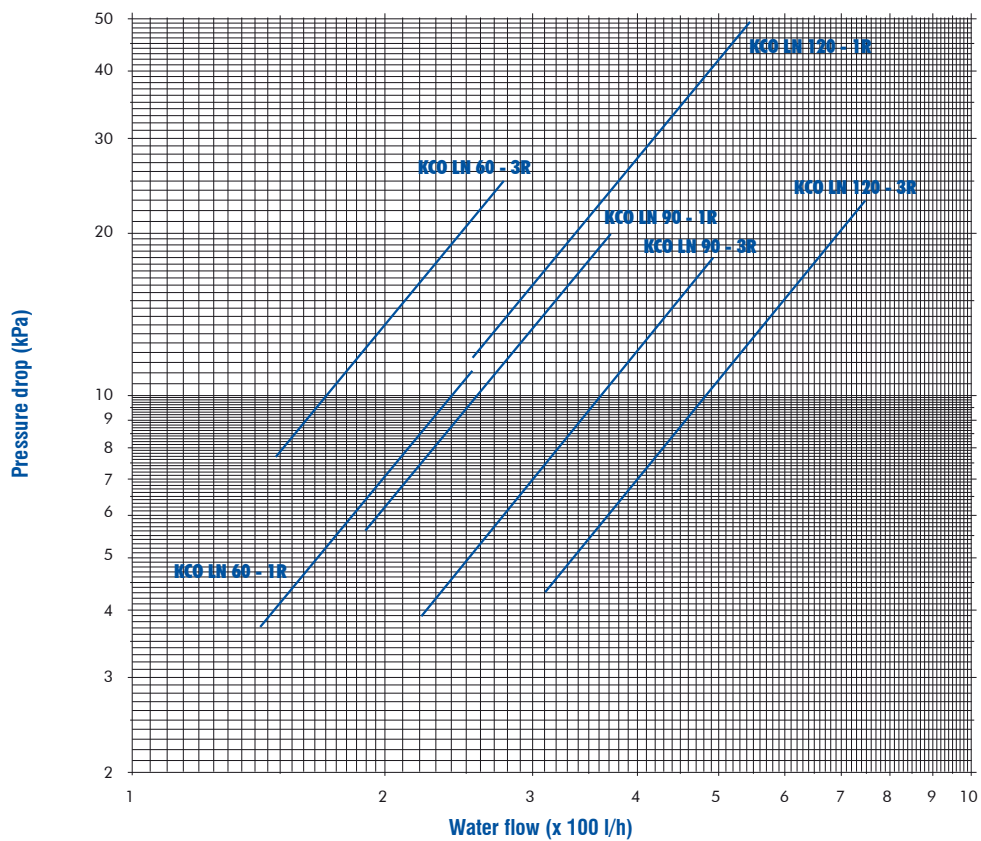



3 models

2-pipe, 2-pipe/2-wire or 4-pipe version

0.8 to 4.3 kW

1.1 to 6.4 kW

> Dimensions and weight - Standard units without height extension <

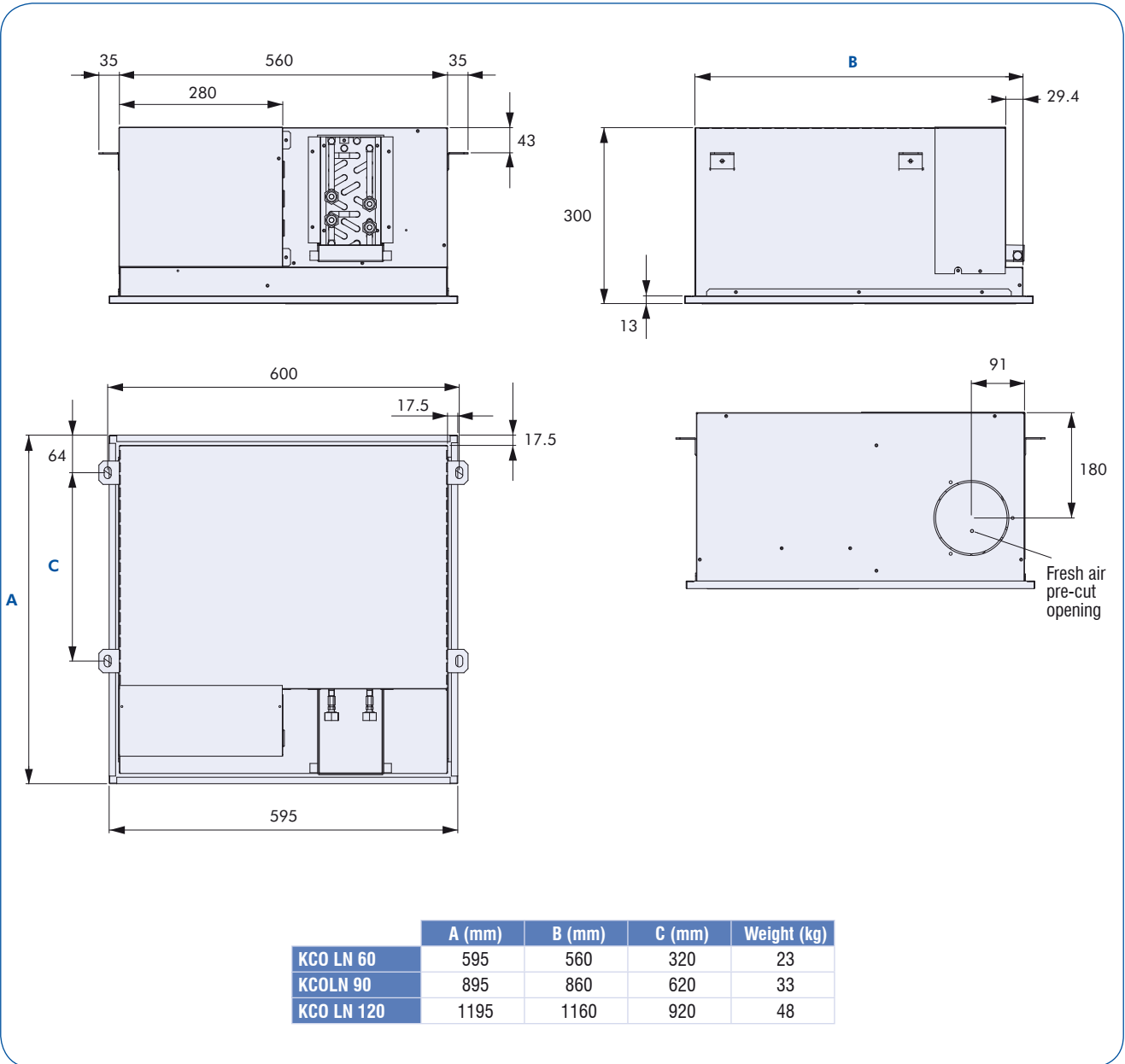

> Dimensions and weight - Units with height extension <

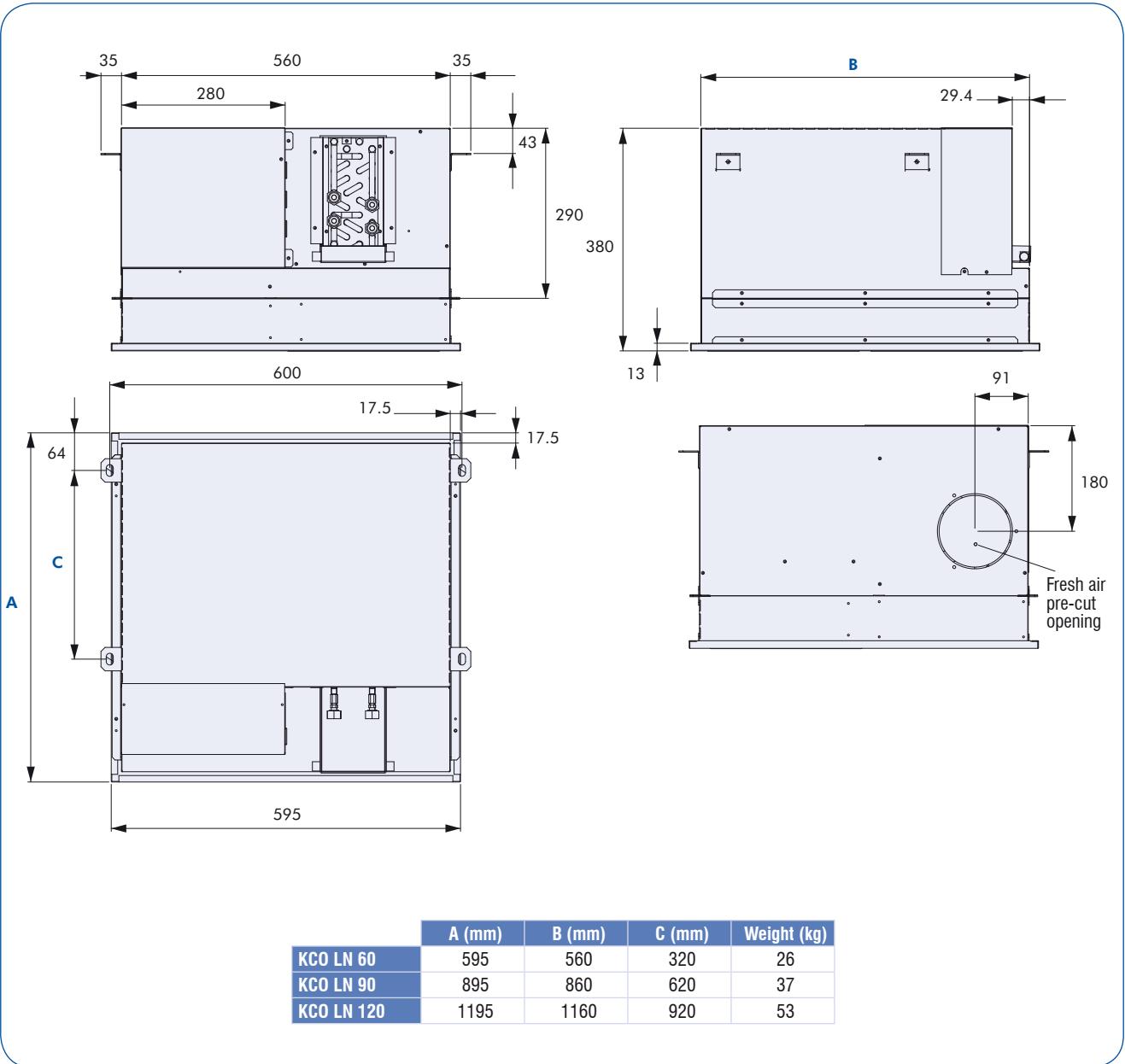



3 models

2-pipe, 2-pipe/2-wire or 4-pipe version

0.8 to 4.3 kW

1.1 to 6.4 kW

> Hydraulic connections (mm) <

Standard units without height extension

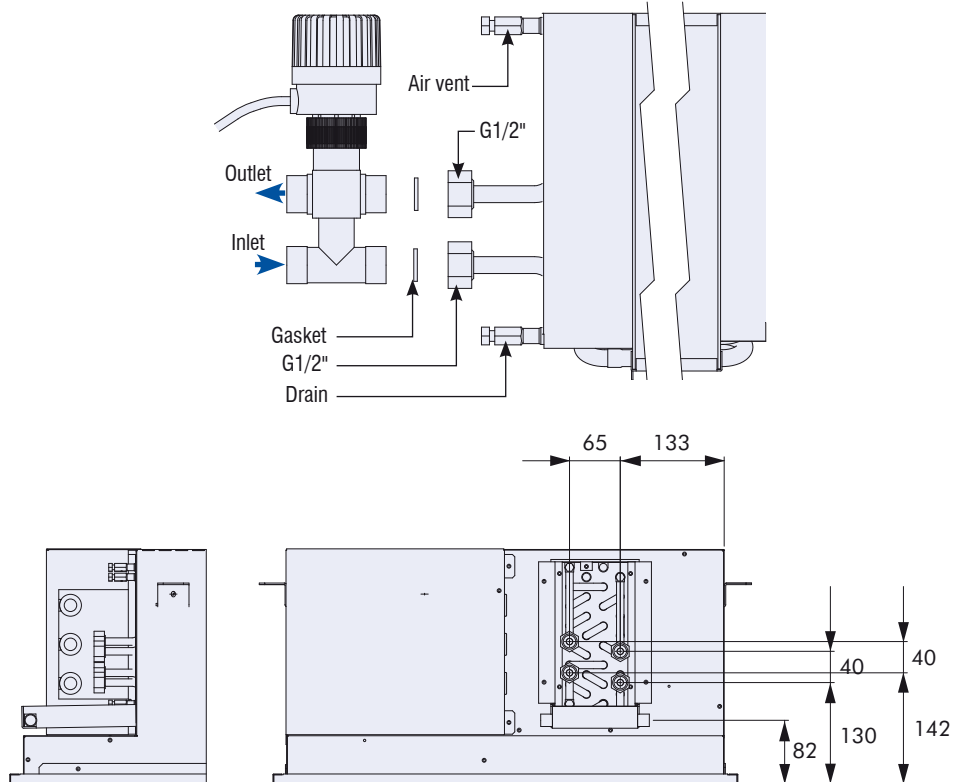

Units with height extension

