



2.2 to 5.0 kW



3.3 to 5.9 kW

**low noise level**

The new chilled water cassettes **9 to 18** offer a comfortable air conditioning at a low installation cost.

Their design and their small dimensions allow them to fit harmoniously into the standard ceiling tiles of 600 x 600 mm size.

These new cassettes have been specially designed for an easy and fast installation, as well as for a great ease of maintenance with a complete access to internal components through the return air grille.

The chilled water cassettes **9 to 18** are available in **3 sizes** (9, 12 & 18) and in **3 versions** (2-pipe, 2-pipe/2-wire and 4-pipe).

> Features and benefits <

- ▶ Casing to be fitted into the false-ceiling has a low profile (287 mm thick) and dimensions compatible with standard ceiling tiles (600 x 600 mm size). The casing is made from galvanized steel sheet with thermal and acoustical insulation, eliminating condensations on the casing and providing low sound levels.
- ▶ Combined discharge and return grille with air filter, discharge manually adjustable on all four sides with possibility of closing one or two faces of discharge, return at the center.
- ▶ Prepunched holes for connection with fresh air intake and connection with a stub duct to treat air of adjacent room. In this case, it becomes necessary to provide a decompression in the adjacent room to allow air return on the cassette.
- ▶ Easy and quick access, by simply removing the front grille, to the internal components such as the coil, the fan-motor assembly, the condensate pump, the optional regulating valve(s) and the electrical box.
- ▶ All connections : water, electrical, condensate drain and air vent cock are located at the same side, on the exterior of the unit.
- ▶ Sliding electrical box is easily accessible after removing two screws. Electrical box has a junction block provided for quick connection on terminals without screws and a multi-output autotransformer supplied for eventual change of fan speeds (on site).
- ▶ Condensate pump supplied as standard, can be easily reached and removed by only one screw; electrical connection by pin type connector. The condensate pump provides a manometric lift up to 600 mm. The pump is, in addition, equipped with a high security level control system : it is concerning a 3-level detection float ("On", "Off" to avoid permanent operation, and "Alarm").
- ▶ Regulating valves (factory-supplied option) mounted inside the casing to limit the works on site and the installation costs.
- ▶ Flexible hoses for connection on units with or without regulating valves.



3 sizes

2-pipe, 2-pipe/2-wire or 4-pipe version



2.2 to 5.0 kW



3.3 to 5.9 kW

> Design features <

Filtration

Cleanable synthetic type air filter (55 % arrestance, G1 class) accessible after opening the return grille.

Ventilation

Centrifugal turbine with direct drive. Motor resiliently mounted and equipped with internal thermal safety device. It can be dismantled by 3 screws, disconnection from supply cable by pin type connector.

Single speed motor connected on 6-output autotransformer which allows to modify eventually the fan speeds on site (3 speeds of ventilation are supplied as standard).

Electrical connection

Fast connection on terminals without screws. Two cable glands are provided on the casing wall allowing to block the supply and control cables.

Supply voltage : 230 V / 1 ph / 50 Hz + earth.

Available accessories and options

Electric heater for use with 2-pipe/2-wire system

It is composed of heating elements located inside the tubes of heat exchanger and is thermally protected against abnormal rises in temperature by two thermostats : automatic reset thermostat and manual reset one.

Supply voltage : 230 V / 1 ph / 50 Hz + earth.

Regulating valves

3-way motorized valves with by-pass (factory-supplied option) for 2-pipe and 4-pipe systems.

Controls

TRM-VP (kit), TRM-FA (kit), TAE 20 (kit), TAE 20 + SEH (kit), Aqu@Simp and Aqu@Net.

> Technical data <

MODELS		9		12		18				
		2-pipe	4-pipe	2-pipe	4-pipe	2-pipe	4-pipe			
Nominal cooling capacity (1)	W	2200	2200	3500	3430	5000	4900			
Nominal heating capacity (2)	W	3300	2200	4600	3200	5900	4900			
AIR FLOW (AVERAGE VALUES)										
Treated air										
- High speed	m ³ /h	700	700	700	700	760	760			
- Medium speed	m ³ /h	460	460	460	460	515	515			
- Low speed	m ³ /h	420	420	420	420	460	460			
- Super low speed	m ³ /h	-	-	-	-	320	320			
Nominal water flow (average values)	m ³ /h	0.378	0.378	0.602	0.59	0.86	0.843			
Water pressure drop (3)	kPa	12	12	17.5	17	15	17.5			
Nominal power supply		230 V / 1 ph / 50 Hz								
Voltage range	V	207 / 253								
POWER INPUT										
Ventilation (HS)	W	49	49	56	56	74	74			
SOUND POWER LEVELS (MEASURED ACCORDING TO ISO 9614 STANDARD)										
		9			12			18		
		Lw global	Lp* global	NR	Lw global	Lp* global	NR	Lw global	Lp* global	NR
- High speed	dBA	50	42	36	52	44	40	57	49	45
- Medium speed	dBA	40	32	26	43	35	30	48	40	37
- Low speed	dBA	38	30	25	40	32	27	42	34	30
- Super low speed	dBA	-	-	-	-	-	-	40	32	28
DIMENSIONS										
Casing (L x P x H)	mm	571 x 571 x 287								
Grille (L x P x H)	mm	625 x 625 x 40								
PACKING										
Gross weight	kg	26	27	28	28	29	29			
Packed volume	m ³	0.15	0.15	0.15	0.15	0.15	0.15			

(1) Nominal conditions : Air : 27 °C/19 °C wet bulb (nominal air flow in high speed). Chilled water : 7 °C/12 °C.

(2) Nominal conditions :

- In 2-pipe configuration : air : 20 °C (nominal air flow in high speed); hot water : entering temperature 50 °C (nominal water flow obtained in cooling mode).
- In 4-pipe configuration : air : 20 °C (nominal air flow in high speed); hot water : 70 °C / 60 °C.

(3) Water pressure drops given for the corresponding nominal water flow on cassettes without control valves.

(*) The sound pressure levels Lp are based on (NR) characteristic of a room having volume of 100 m³ with reverberation time of 0.5 seconds.

> Technical data (continued) <

Water connections

Models		9	12	18
Contents	l	1.3	1.3	2
Maximum operating pressure	bar	15	15	15
Test pressure	bar	24	24	24
Couplings (2-pipe system)	Ø	1/2" gas male	1/2" gas male	3/4" gas male
	mm	15-21 male	15-21 male	20-27 male
Couplings (4-pipe system)	Ø	1/2" gas male	1/2" gas male	1/2" gas male (heating) 3/4" gas male (cooling)
	mm	15 - 21 male	15 - 21 male	15 - 21 male (heating) 20 - 27 male (cooling)

Electrical data

Models		9 - 2-pipe		12 - 2-pipe		18 - 2-pipe	
		With BE	Without BE	With BE	Without BE	With BE	Without BE
Nominal current	A	6.8	0.3	10.2	0.36	11.8	0.5
Maximum current	A	8.3	0.36	12.3	0.51	14.3	0.67
Fuse rating aM**	A	10	1	16	1	16	1
Fuse rating ASE/VDE	A	10	2	16	2	16	2
Cable section*	mm ²	3 x 1	3 x 1	3 x 1.5	3 x 1	3 x 1.5	3 x 1
Electric heater capacity (230 V single phase)	W	1500	-	2250	-	2600	-

Models		9 - 4-pipe	12 - 4-pipe	18 - 4-pipe
Nominal current	A	0.3	0.36	0.5
Maximum current	A	0.36	0.51	0.67
Fuse rating aM**	A	1	1	1
Fuse rating ASE/VDE	A	2	2	2
Cable section*	mm ²	3 x 1	3 x 1	3 x 1

BE : Electric heater.

* Minimum section to be adapted according to local regulations and norms.

** Or circuit breaker curve C.

Operating limits - Use of chilled water

Lower limits			
Indoor temperature	°C	Thi	13
		Tsi	17
Water temperature	°C	Twe	3

Higher limits			
Indoor temperature	°C	Thi	13
		Tsi	32
Water temperature	°C	Twe	18

Thi : Indoor wet bulb temperature.

Twe : Entering water temperature.

Tsi : Indoor dry bulb temperature.

Operating limits - Use of hot water

Maximum indoor temperature	°C	Thi	22
		Tsi	32
Maximum entering water temperature	°C	Twe	70 (1) (2)

Thi : Indoor wet bulb temperature.

Twe : Entering water temperature for 2 or 4-pipe systems.

Tsi : Indoor dry bulb temperature.

(1) : For reversible 2-pipe system with extra electric heater energized, maximum Twe is 35 °C.

(2) : For applications with water temperature higher than 70 °C, consult factory.

Fresh air intake

Fresh air flow should not exceed 12 % of nominal air flow (see table below).

An antifreeze thermostat, switching off the external fan at +5 °C, must be used on fresh air intake during winter period.

A filter, fan and insulated air duct are to be provided on site.

Models		9	12	18
Nominal air flow in high speed	m ³ /h	700	700	760
Maximum fresh air flow	m ³ /h	80	80	90



3 sizes

2-pipe, 2-pipe/2-wire or 4-pipe version



2.2 to 5.0 kW



3.3 to 5.9 kW

> Cooling capacities <

Chilled water standard coil - 2-pipe system

Water conditions	Entering air temperature	Size 9			Size 12			Size 18				
		Air flow (m³/h)			Air flow (m³/h)			Air flow (m³/h)				
		LS	MS	HS	LS	MS	HS	SLS	LS	MS	HS	
		420	460	700	420	460	700	320	460	515	760	
6 / 11 °C	27°C Total capacity	W	1800	1930	2430	2630	2800	3850	2730	3650	4100	5600
	50% Sensible capacity	W	1360	1450	1870	1890	2030	2840	1850	2560	2850	4000
	25°C Total capacity	W	1560	1630	2060	2260	2400	3270	2340	3150	3480	4800
	50% Sensible capacity	W	1210	1280	1650	1680	1800	2510	1650	2270	2520	3560
	23°C Total capacity	W	1200	1260	1610	1720	1870	2530	1840	2450	2710	3740
	50% Sensible capacity	W	1050	1110	1550	1450	1570	2190	1440	1970	2190	3090
7 / 12 °C	27°C Total capacity	W	1650	1740	2200	2390	2560	3500	2490	3370	3740	5000
	47% Sensible capacity	W	1290	1370	1770	1790	1930	2700	1760	2430	2700	3780
	25°C Total capacity	W	1370	1450	1830	1990	2160	2910	2090	2820	3120	4270
	50% Sensible capacity	W	1130	1200	1560	1560	1700	2370	1540	2130	2370	3330
	23°C Total capacity	W	1010	1070	1360	1480	1580	2150	1570	2150	2380	3260
	50% Sensible capacity	W	970	1030	1350	1340	1440	2010	1320	1830	2040	2870
8 / 13 °C	27°C Total capacity	W	1470	1560	1950	2150	2290	3100	2240	3020	3340	4540
	50% Sensible capacity	W	1220	1300	1680	1690	1820	2540	1650	2280	2530	3560
	25°C Total capacity	W	1180	1250	1580	1730	1830	2520	1830	2460	2720	3730
	50% Sensible capacity	W	1050	1120	1460	1460	1570	2210	1430	1980	2200	3100
	23°C Total capacity	W	880	930	1210	1280	1380	1890	1350	1860	2050	2830
	50% Sensible capacity	W	880	930	1210	1240	1330	1870	1220	1700	1890	2660
10 / 15 °C	27°C Total capacity	W	1090	1150	1450	1610	1740	2360	1720	2320	2570	3530
	50% Sensible capacity	W	1070	1140	1450	1470	1590	2220	1440	1990	2220	3140
	25°C Total capacity	W	890	940	1220	1270	1370	1890	1340	1840	2060	2820
	50% Sensible capacity	W	890	940	1220	1250	1350	1890	1230	1710	1910	2690
	23°C Total capacity	W	720	770	1000	1010	1120	1550	1030	1420	1580	2240
	50% Sensible capacity	W	720	770	1000	1010	1120	1550	1030	1420	1580	2240

Chilled water coil - 4-pipe system

Water conditions	Entering air temperature	Size 9			Size 12			Size 18				
		Air flow (m³/h)			Air flow (m³/h)			Air flow (m³/h)				
		LS	MS	HS	LS	MS	HS	SLS	LS	MS	HS	
		420	460	700	420	460	700	320	460	515	760	
6 / 11 °C	27°C Total capacity	W	1800	1930	2430	2570	2770	3790	2710	3650	4000	5380
	50% Sensible capacity	W	1360	1450	1870	1850	2000	2800	1850	2550	2810	3900
	25°C Total capacity	W	1560	1630	2060	2190	2360	3240	2300	3100	3400	4600
	50% Sensible capacity	W	1210	1280	1650	1640	1760	2480	1640	2250	2490	3460
	23°C Total capacity	W	1200	1260	1610	1690	1820	2510	1780	2450	2630	3560
	50% Sensible capacity	W	1050	1110	1550	1420	1530	2160	1410	1960	2150	3000
7 / 12 °C	27°C Total capacity	W	1650	1740	2200	2340	2510	3430	2460	3300	3660	4900
	47% Sensible capacity	W	1290	1370	1770	1760	1900	2650	1750	2400	2680	3700
	25°C Total capacity	W	1370	1450	1830	1950	2090	2880	2050	2750	3030	4010
	50% Sensible capacity	W	1130	1200	1560	1520	1650	2330	1530	2100	2330	3210
	23°C Total capacity	W	1010	1070	1360	1430	1550	2140	1560	2100	2310	3130
	50% Sensible capacity	W	970	1030	1350	1300	1420	1990	1310	1820	2010	2800
8 / 13 °C	27°C Total capacity	W	1470	1560	1950	2090	2240	3060	2200	2950	3240	4310
	50% Sensible capacity	W	1220	1300	1680	1650	1780	2500	1640	2260	2500	3460
	25°C Total capacity	W	1180	1250	1580	1690	1830	2480	1790	2450	2640	3560
	50% Sensible capacity	W	1050	1120	1460	1430	1550	2170	1420	1960	2160	3020
	23°C Total capacity	W	880	930	1210	1250	1350	1870	1300	1810	1990	2720
	50% Sensible capacity	W	880	930	1210	1210	1310	1840	1200	1680	1860	2590
10 / 15 °C	27°C Total capacity	W	1090	1150	1450	1560	1680	2310	1690	2290	2510	3360
	50% Sensible capacity	W	1070	1140	1450	1430	1540	2180	1430	1990	2190	3060
	25°C Total capacity	W	890	940	1220	1250	1350	1850	1300	1810	1990	2700
	50% Sensible capacity	W	890	940	1220	1220	1320	1850	1210	1700	1880	2610
	23°C Total capacity	W	720	770	1000	990	1070	1510	1000	1390	1560	2150
	50% Sensible capacity	W	720	770	1000	990	1070	1510	1000	1390	1560	2150

> Heating capacities <

Hot water standard coil - 2-pipe system

Water conditions	Entering air temperature	Size 9			Size 12			Size 18			
		Air flow (m ³ /h)			Air flow (m ³ /h)			Air flow (m ³ /h)			
		LS	MS	HS	LS	MS	HS	SLS	LS	MS	HS
		420	460	700	420	460	700	320	460	515	760
70 / 60 °C	19 °C Heating capacity W	4060	4350	5920	5370	5780	8030	5140	6950	7640	10100
	20 °C Heating capacity W	3970	4250	5800	5250	5650	7840	5030	6810	7470	9890
	21 °C Heating capacity W	3880	4150	5670	5140	5520	7660	4930	6670	7310	9670
50 / 40 °C	19 °C Heating capacity W	2180	2330	3200	2940	3140	4370	2880	3860	4220	5520
	20 °C Heating capacity W	2090	2240	3070	2830	3020	4180	2770	3720	4050	5300
	21 °C Heating capacity W	2010	2130	2940	2700	2910	3990	2650	3550	3870	5070

Hot water coil - 4-pipe system

Water conditions	Entering air temperature	Size 9			Size 12			Size 18			
		Air flow (m ³ /h)			Air flow (m ³ /h)			Air flow (m ³ /h)			
		LS	MS	HS	LS	MS	HS	SLS	LS	MS	HS
		420	460	700	420	460	700	320	460	515	760
70 / 60 °C	19 °C Heating capacity W	1840	1930	2250	2460	2590	3280	2760	3560	3870	5020
	20 °C Heating capacity W	1800	1900	2200	2400	2500	3200	2700	3480	3700	4900
	21 °C Heating capacity W	1760	1830	2140	2330	2470	3130	2630	3400	3690	4790
50 / 40 °C	19 °C Heating capacity W	890	920	1090	1260	1330	1680	1460	1870	2020	2610
	20 °C Heating capacity W	840	880	1040	1210	1280	1600	1390	1790	1930	2510
	21 °C Heating capacity W	800	830	970	1150	1210	1520	1330	1700	1850	2400



3 sizes

2-pipe, 2-pipe/2-wire or 4-pipe version

2.2 to 5.0 kW

3.3 to 5.9 kW

> Water pressure drops - Size 9 - 2 rows - 2 circuits <

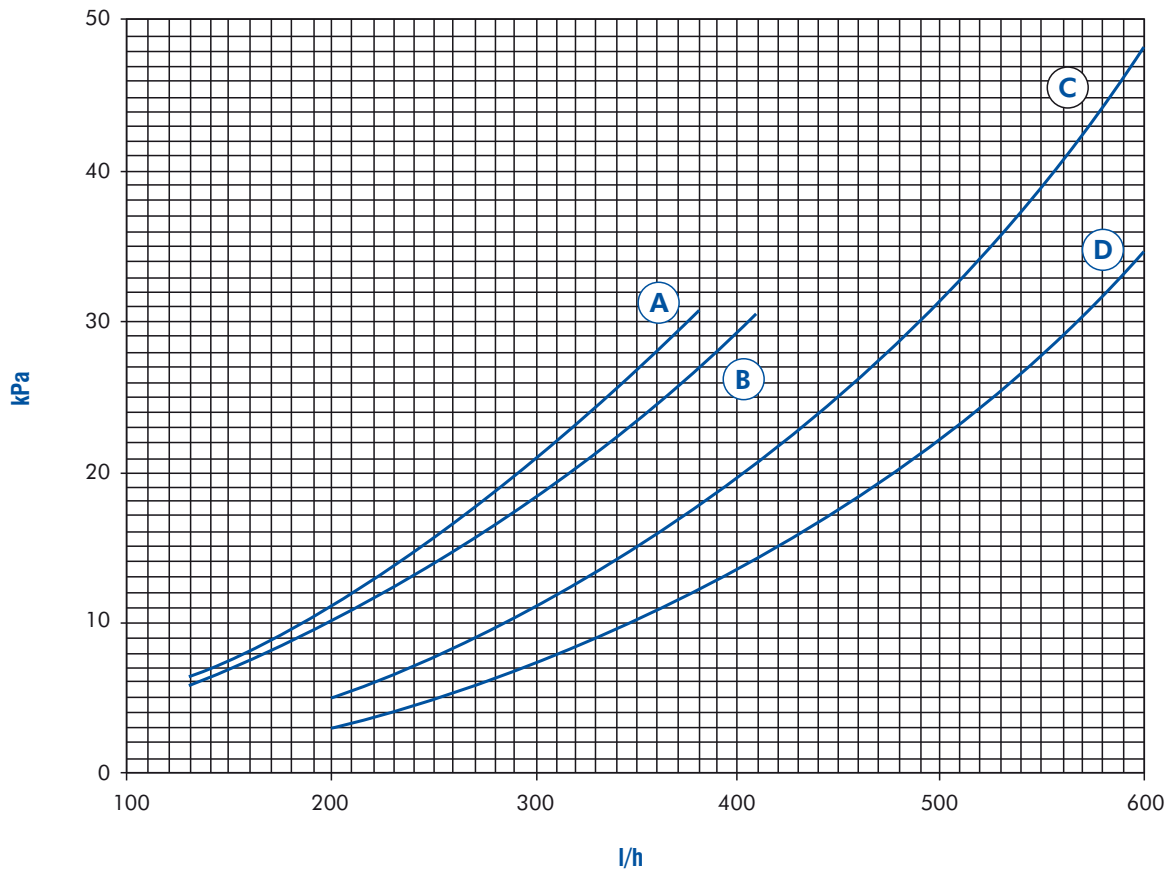

- Curve A** : Pressure drop of heating circuit with control valve (4-pipe system).
- Curve B** : Pressure drop of heating circuit without control valve (4-pipe system).
- Curve C** : Pressure drop of cooling circuit with control valve (2 and 4-pipe systems).
- Curve D** : Pressure drop of cooling circuit without control valve (2 and 4-pipe systems).

T _{wm} (°C) / % Glycol	K : Glycol factor				
	10	20	30	40	50
3	1.135	1.234	1.385	1.53	1.85
5	1.13	1.23	1.38	1.51	1.77
10	1.12	1.22	1.37	1.47	1.66
15	1.11	1.19	1.36	1.46	1.64
20	1.1	1.18	1.35	1.44	1.59
25	1.09	1.17	1.33	1.43	1.57
30	1.08	1.16	1.31	1.42	1.56
35	1.07	1.15	1.29	1.41	1.54
40	1.06	1.14	1.28	1.4	1.52
45	1.05	1.13	1.25	1.37	1.49
50	1.04	1.12	1.22	1.34	1.47
55	0.99	1.1	1.2	1.31	1.44
60	0.94	1.09	1.19	1.28	1.42

T_{wm} : Average temperature of the mixture.

ΔP_{w0} : Pure water pressure drop.

ΔP_w : Brine water pressure drop.

ΔP_w : K x ΔP_{w0}.

T _{se} (°C) / % Glycol	10	20	30	40	50
-25					yes
-20				yes	yes
-15				yes	yes
-10			yes	yes	yes
-5		yes	yes	yes	yes
0	yes	yes	yes	yes	yes
5	yes	yes	yes	yes	yes

T_{se} : Outdoor dry bulb temperature.

> Water pressure drops - Size 12 - 2 rows - 3 circuits <

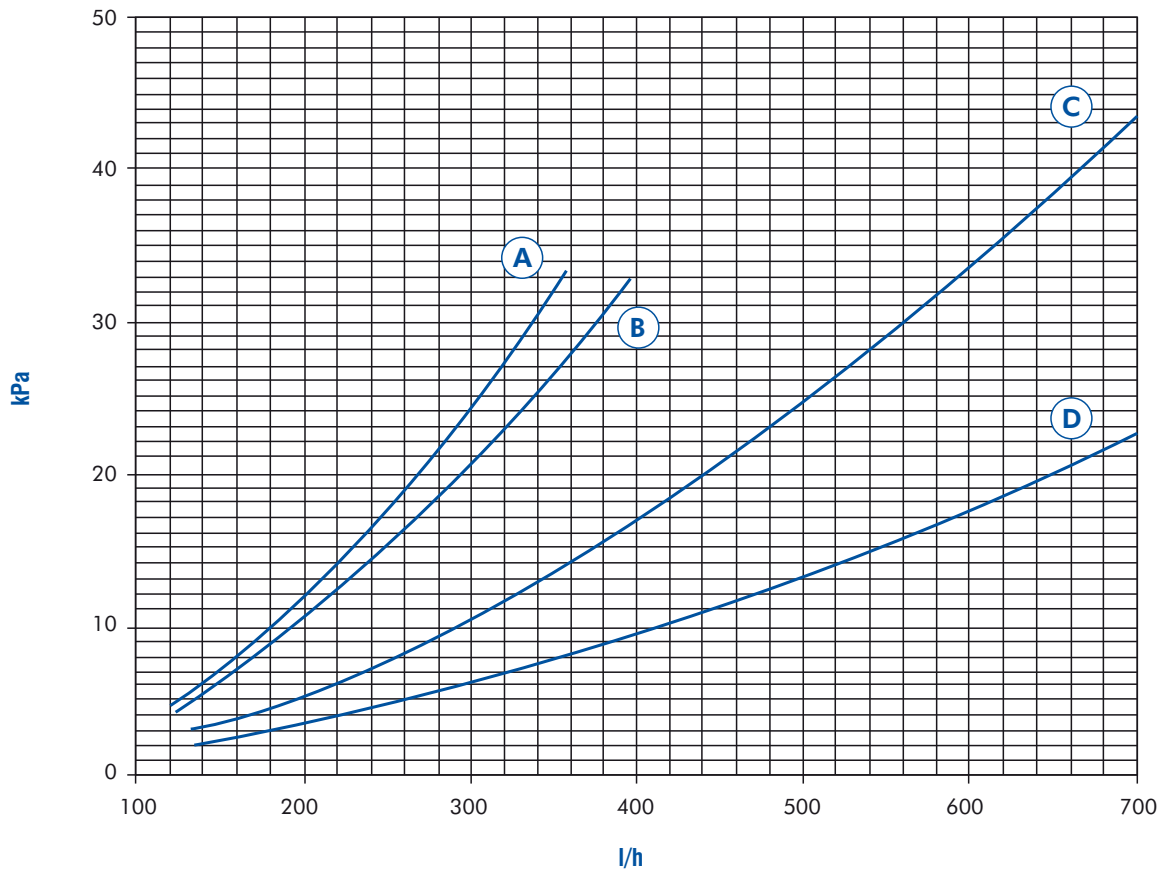

- Curve A** : Pressure drop of heating circuit with control valve (4-pipe system).
- Curve B** : Pressure drop of heating circuit without control valve (4-pipe system).
- Curve C** : Pressure drop of cooling circuit with control valve (2 and 4-pipe systems).
- Curve D** : Pressure drop of cooling circuit without control valve (2 and 4-pipe systems).



3 sizes

2-pipe, 2-pipe/2-wire or 4-pipe version

2.2 to 5.0 kW

3.3 to 5.9 kW

> Water pressure drops - Size 18 - 3 rows - 4 circuits <

2-pipe system

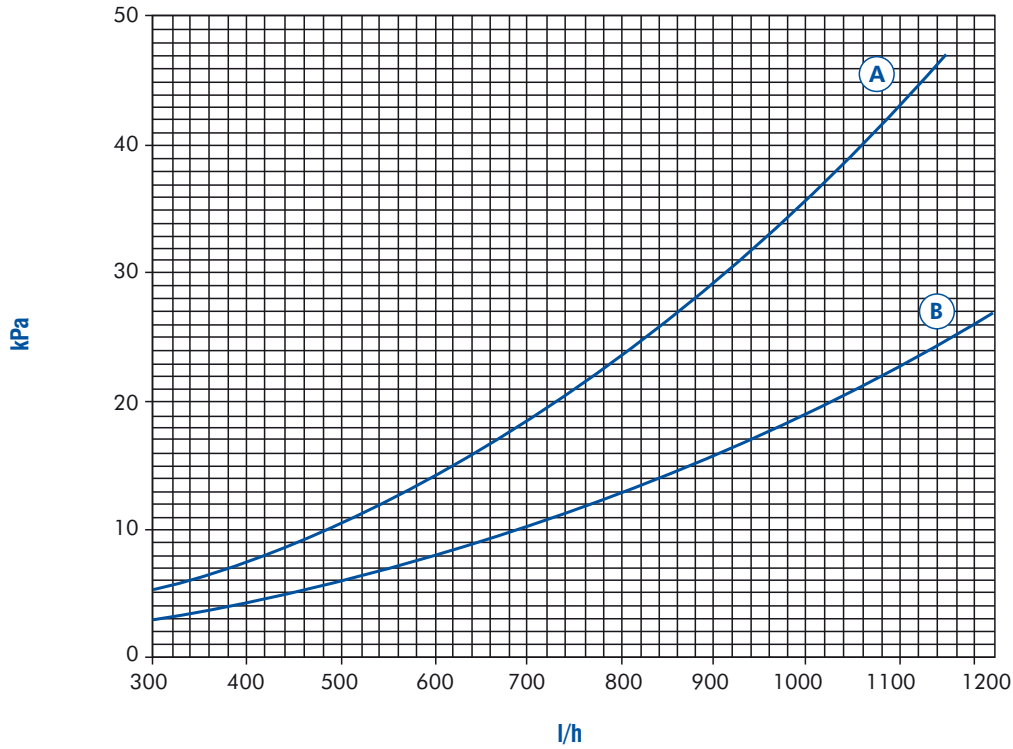

- Curve A** : Pressure drop of heating/cooling circuit with control valve.
- Curve B** : Pressure drop of heating/cooling circuit without control valve.

> Water pressure drops - Size 18 - 3 rows - 4 circuits <

4-pipe system

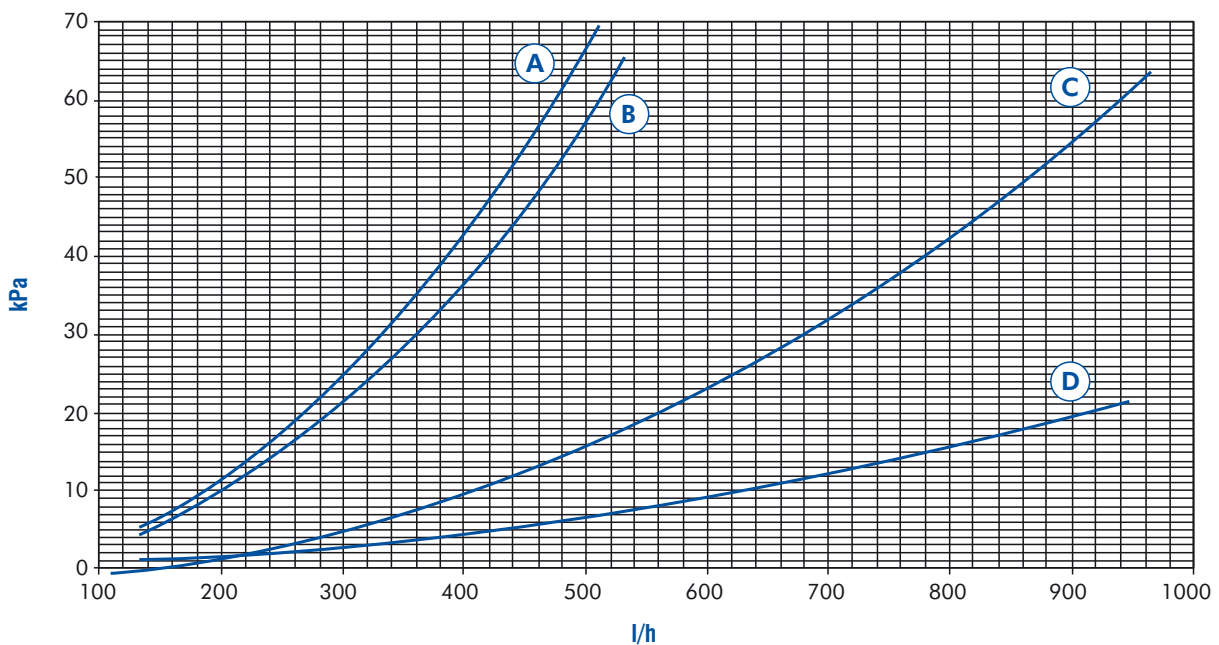

- Curve A** : Pressure drop of heating circuit with control valve.
- Curve B** : Pressure drop of heating circuit without control valve.
- Curve C** : Pressure drop of cooling circuit with control valve.
- Curve D** : Pressure drop of cooling circuit without control valve.

> Dimensions - 2-pipe system <

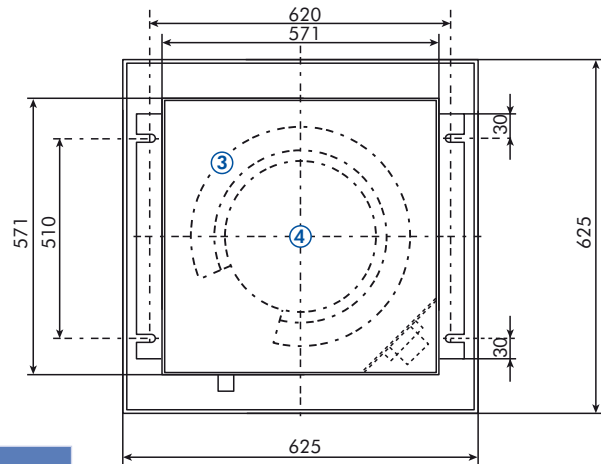
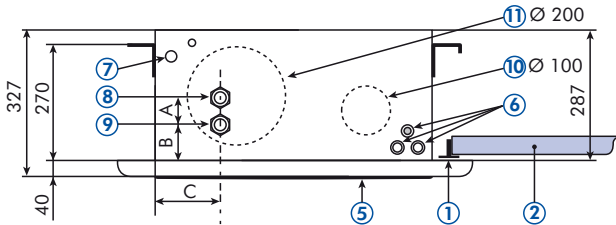

LEGEND	
1	T-shaped rod (false ceiling)
2	False ceiling
3	Coil
4	Fan
5	Suction grille
6	Electrical connection
7	Condensate drain (Ø15)
8	Water leaving gas male coupling (refer to table "water connections")
9	Water entering gas male coupling (refer to table "water connections")
10	Fresh air intake
11	Opening for air diffusion through a duct into the adjacent room (pre-punched)

Sizes	9 2-pipe	12 2-pipe	18 2-pipe
A	39 mm	39 mm	50 mm
B	120 mm	113 mm	95 mm
C	118 mm	120 mm	102 mm

> Dimensions - 4-pipe system <

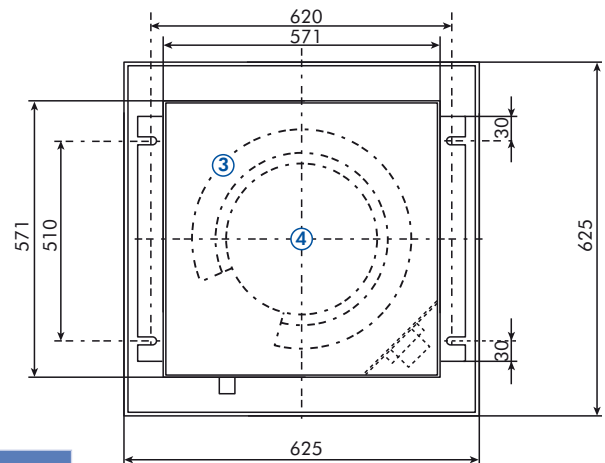
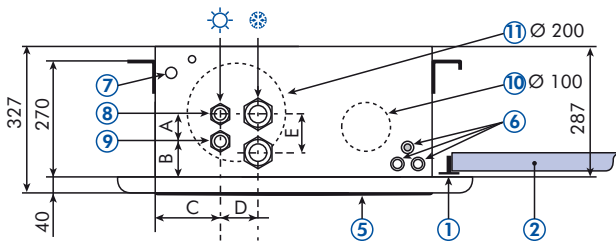

LEGEND	
1	T-shaped rod (false ceiling)
2	False ceiling
3	Coil
4	Fan
5	Suction grille
6	Electrical connection
7	Condensate drain (Ø15)
8	Water leaving gas male coupling (refer to table "water connections")
9	Water entering gas male coupling (refer to table "water connections")
10	Fresh air intake
11	Opening for air diffusion through a duct into the adjacent room (pre-punched)

Sizes	9 4-pipe	12 4-pipe	18 4-pipe
A	39 mm	39 mm	39 mm
B	120 mm	113 mm	106 mm
C	28 mm	70 mm	80 mm
D	50 mm	50 mm	50 mm
E	39 mm	39 mm	50 mm