



The **Aqu@net** electronic control system has been specifically designed for wall mounted, ceiling mounted or cassette type fan coil units, all with full air recycling, for the following applications : **2-pipe cooling only, 2-pipe heating only, 2-pipe / 2-wire, 2-pipe reversible with or without additional electrical heating and 4-pipe installations.**

The system comprises an FCC controller integrated in the fan coil unit and an RCL control, capable of being fitted as an option to our entire range of low wall mounted fan coil units.

Aqu@net is a new generation of communicating electronic control via a proprietary bus using an easily installed additional PCB and a supervision station known as **μBMS** (refer to the manual relating to this supervision station).

Furthermore, in the case of small installations, this control system enables a master / slave network to be created very easily by means of hardwired connections, and it enables up to 15 units to be controlled with a single RCL control.

## > The Aqu@Net electronic control system <

The Aqu@net electronic control system has been designed to achieve an optimised compromise between running costs (heating valve for integral proportional control), ergonomics and performance.

It is compatible with the μBMS supervision station and communicates via a proprietary bus, as well as being capable of operating without a supervision station.

The Aqu@net electronic control system can be adapted to the following air conditioning system models :

- Model A** : For 2-pipe heating only or cooling only fan coil units with manual changeover.
- Model B** : For 2-pipe reversible fan coil units with automatic changeover (pipe work probe).
- Model C** : For 2-pipe / 2-wire fan coil units.
- Model D** : For 2-pipe reversible fan coil units with automatic changeover (pipe work probe) and additional electrical heating.
- Model E** : For 4-pipe fan coil units.

### FCC controller description

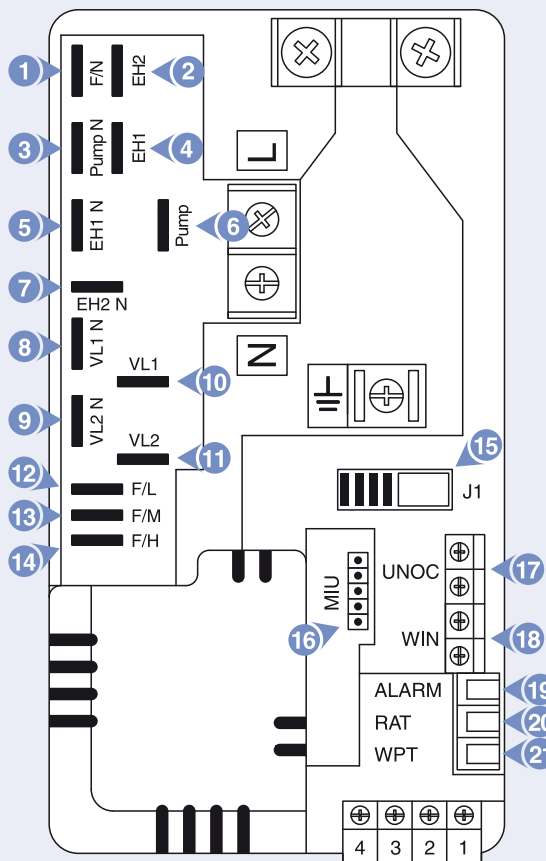

- 1 F/N** Fan motor neutral.
- 2 EH2** N°2 electrical resistance phase.
- 3 Pump N** Condensate lift pump supply neutral.
- 4 EH1** N°1 electrical resistance phase.
- 5 EH1 N** N°1 electrical resistance neutral.
- 6 Pump** Condensate lift pump supply phase.
- 7 EH2 N** N°2 electrical resistance neutral.
- 8 VL1 N** Valve N°1 neutral (Cooling or heating or reversible valve).
- 9 VL2 N** Valve N°2 neutral (Heating valve 4 pipe system).
- 10 VL1** Valve N°1 phase (Cooling or heating or reversible valve).
- 11 VL2** Valve N°2 phase (Heating valve 4 pipe system).
- 12 F/L** Fan motor low speed phase.
- 13 F/M** Fan motor medium speed phase.
- 14 F/H** Fan motor high speed phase.
- 15 J1** Model plug configuration and location block.
- 16 MIU** Connection for additional specific interface board.
- 17 UNOC** Input terminal block for normally open clock dry contact switch (open = occupation mode).
- 18 WIN** Input terminal block for normally closed window dry contact switch (open = window open).
- 19 ALARM** Special terminals (supplied shunted on the fan coil units) for connection to a condensate pump upper level contact switch.
- 20 RAT** Intake air temperature, red connector and red wire always wired at factory.
- 21 WPT** Water pipe temperature, white connector, black wire, wired at factory for reversible systems.



## > The Aqu@Net electronic control system (continued) <

### RCL control description

The RCL control has been designed specifically for use with fan coil units equipped with the Aqu@net system.

It operates independently on units equipped with an FCC controller, irrespective of the configuration (A, B, C, D, E).

When the electrical connections have been made correctly, the digital display indicates the set temperature, the operating mode and the ventilation speed.

**Comment :** If a  $\mu$ BMS supervision module or a BMS is used, the parameters displayed are not necessarily those used currently by the Aqu@Net regulator.

The RCL control is only capable of displaying parameters changed on the control itself and is not capable of displaying parameters changed on a  $\mu$ BMS supervision module or a BMS.

**IMPORTANT :** Before commissioning the appliance, connect the RCL control to the FCC regulator via the blue connector (AQU@FAN + RCL fitted to the appliance).



#### WARNING

In the event of a power cut, the RCL control can retain and display operating mode, ventilation speed and set temperature data for 10 minutes.

Beyond 10 minutes, the digital display is cleared and the data is lost.

As soon as the electrical supply is re-established, the digital display re-starts in default mode, at 24 °C in Cooling mode. However, despite this default mode being displayed, it is not used by the base unit.

All the operating parameters will be saved by the base unit and this enables the unit to re-start in the previously programmed mode and in the operating conditions.

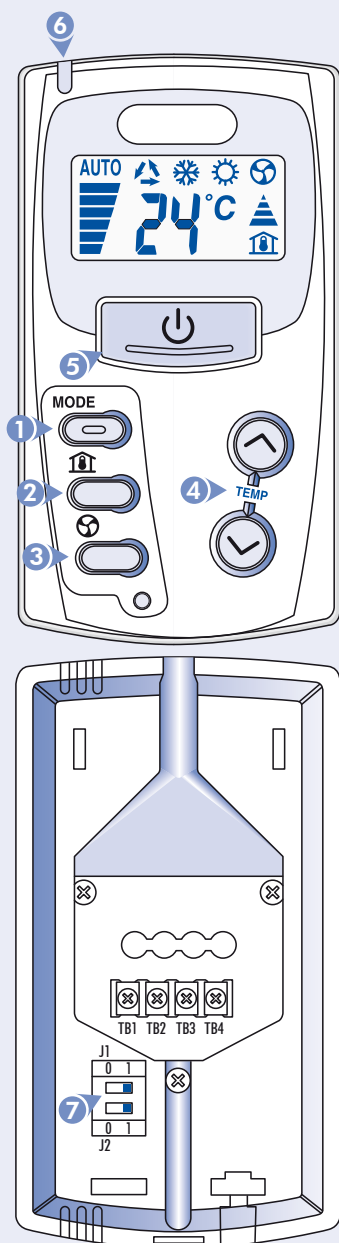

**Dimensions :** H = 11 cm, L = 6 cm, Depth = 1.5 cm.

- |          |                   |   |
|----------|-------------------|---|
| <b>1</b> | <b>MODE</b>       | By successive presses, this key enables the desired operating mode to be selected (according to the settings on the mode selection block - refer to section "Various control systems").   |
|          | <br><br><br><br>  | Ventilation mode only.<br>Cooling mode (Summer).<br>Heating mode (Winter).<br>Automatic operating mode selection (in Heating or Cooling mode).<br>Sending data to the FCC controller or blocked keypad signal.  |
| <b>2</b> |                   | By successive presses, this key enables the displayed temperature to be selected.<br><br>A pictogram representing a house appears when the room temperature is displayed.<br><br>If the house is not present, then the desired room temperature is being displayed.   |
| <b>3</b> | <br><br>          | By successive presses, this key enables the ventilation speed to be selected :<br><br>- Low speed (2 bars)<br>- Medium speed (4 bars)<br>- High speed (6 bars)<br>- Automatic speed (6 bars + AUTO)   |
| <b>4</b> | <b>TEMP</b>       | These keys enable the desired temperature in the room to be raised or lowered (set temperature).  |
| <b>5</b> |                   | By successive presses, this key enables the fan coil units to be started or moved into standby mode. The standby/off status is indicated by a green LED.  |
| <b>6</b> | <b>GREEN LED</b>  | On : Fan coil unit running.<br>Off : Fan coil unit stopped.<br>Slow flashing : Unoccupied mode activated.<br>Rapid flashing : Condensate level alarm.   |
| <b>7</b> | <b>DIPS J1-J2</b> | These DIP switches enable the RCL to be configured in accordance with your system's application (Refer to section "Various control systems" for further details). To gain access to these DIP switches, the RCL has to be carefully removed from its support bracket. |

## > Definition of standard functions <

### "WIN" window contact switch and "UNOC" unoccupied functions

#### Window contact switch function :

The FCC controller has 2 terminals (5 and 6) marked WIN, intended to be connected to an opening contact switch for activating the window contact switch function (window closed = contact switch closed).

The window contact switch function stops the fan coil unit (valve or electrical resistance cut) and moves the unit into cyclical ventilation mode with an anti-freezing heating temperature protection set at 8 °C.

**IMPORTANT :** In all cases, the electrical resistance post-ventilation function is maintained.

#### Unoccupied function :

The FCC controller has 2 terminals (7 and 8) marked UNOC, intended to be connected to a closing contact switch for activating the unoccupied function (contact switch closed = function activated).

The aim of the unoccupied function is to replace the temperatures set by the user with factory-programmed set temperatures :

- Cooling mode set temperature : 30 °C.
- Heating mode set temperature : 14 °C.
- Cyclical ventilation.

**Note :** For savings in costs and materials, it is possible to use a single dry contact switch for several FCC controllers (refer to example below).

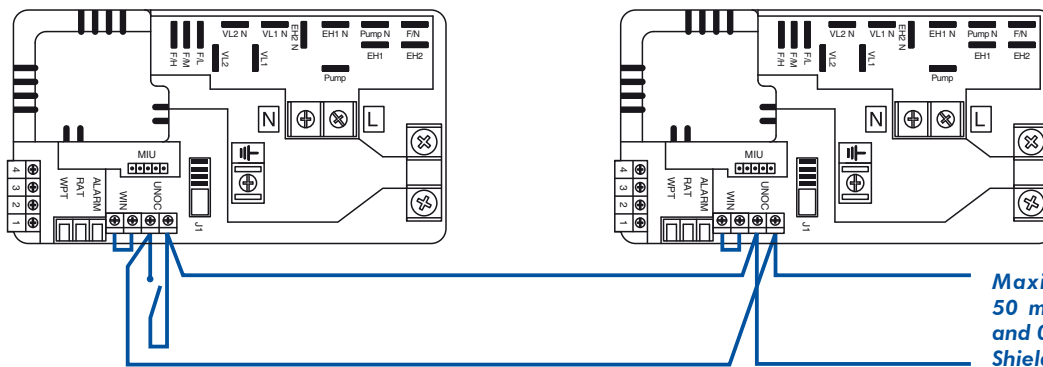

up to 10 fan coil units

Maximum cable length :  
50 metres, Ø between 0.4  
and 0.65 mm.  
Shielded AWG26 to AWG22.

### "WPT" water temperature probe

It is only fitted to B and D type systems. It enables mode changing in relation to water temperature that is measured via a probe on the pipe work. For this reason, special care must be taken when assembling this probe.

**This probe must be fitted with a 4 way valve and upstream of the valve on the water inlet** (refer to diagram below).

We recommend that the probe is fitted with an electrician's type collar, using contact paste and thermal insulation on the pipe work.

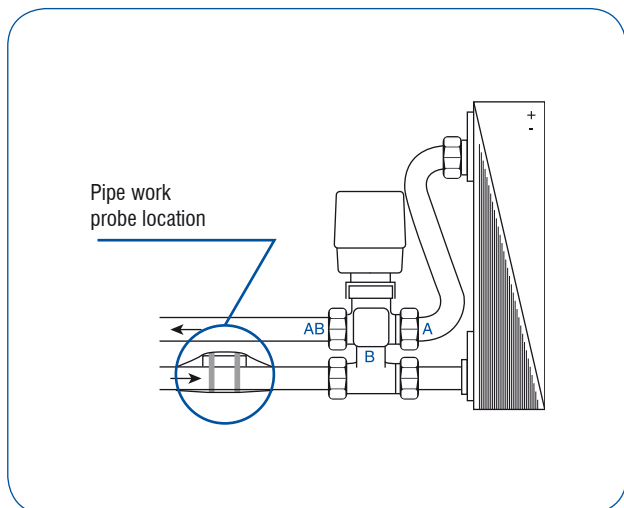

### "RAT" intake air temperature probe

The intake air temperature probe enables the fan coil unit to be controlled by the air temperature reigning around the unit.

The major advantage of this system is that several units can be controlled with a single RCL control.

This probe is connected at the factory in all cases and is installed on the fan air intake.

### "ALARM" condensate upper level alarm probe

In the case of fan coil units, this connector is systematically supplied with a shunt and it not used.

In the case of chilled water cassettes, this contact switch is connected to the condensate tray upper level contact switch. This switch's function is to shut down the cassette (ventilation and valve). Its operation is visualised by a rapid flashing of the LED on the RCL control.



## > Various control systems <

### Configurations

The model plugs supplied on the J1 block of the FCC control and identified by different colours, enable the following control systems to be obtained :

- Model A** : For 2-pipe heating only or cooling only fan coil units with manual changeover.
- Model B** : For 2-pipe reversible fan coil units with automatic changeover (pipe work probe).
- Model C** : For 2-pipe / 2-wire fan coil units.

**Model D** : For 2-pipe reversible fan coil units with automatic changeover (pipe work probe) and electric heating.

**Model E** : For 4-pipe fan coil units.

Each model plug is specific to a chosen control system.

On the RCL control, it is possible to set the DIP switches J1 and J2 to limit mode access.

**RCL control factory settings** : J1 on 0, J2 on 0 with all modes accessible, including on unit mounted RCL control. Refer to the chart for settings optimisation.

#### FCC controller

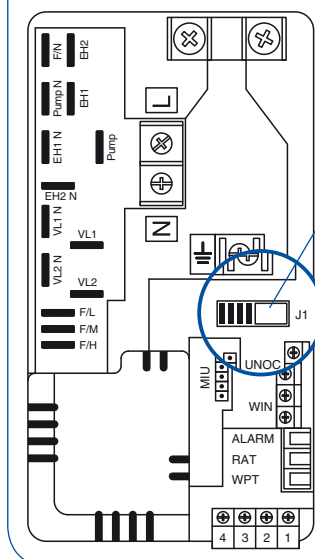

Model plug location with different colours according to applications. (Refer to table below).

#### RCL control

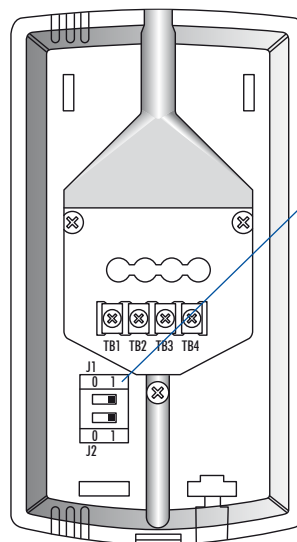

DIP switches J1 and J2 settings accessible at the rear of the control (Refer to table below).

Model plug colour on FCC	Application	System	Action				Water probe		Preferable settings on RCL control				Accessible modes				
			Valve		Ventilation		Yes	No	Dip J1		Dip J2		Off	Cool	Heat	Auto	Fan
			Yes	No	Yes	No			0	1	0	1					
Black	2-pipe / cooling only	A	✓		✓		✓		✓	✓		✓	✓				✓
Blue	2-pipe / cooling only IFC (1)	A		✓	✓		✓		✓	✓		✓	✓				
Green	2-pipe / heating only	A	✓		✓		✓		✓		✓	✓		✓			✓
Green	2-pipe / heating only + PBTEE (2)	A	✓		✓		✓		✓		✓	✓		✓			✓
Red	2-pipe / heating only IFC (1)	A		✓	✓		✓		✓		✓	✓		✓			
Red	2-pipe / heating only IFC (1) + PBTEE (2)	A		✓	✓		✓		✓		✓	✓		✓			
White	4-pipe	E	✓		✓		✓		✓		✓	✓				✓	✓
White	2-pipe reversible / 2-wire	D	✓		✓		✓		✓		✓	✓		✓	✓	✓	✓
Orange	2-pipe reversible	B	✓		✓		✓		✓		✓	✓		✓	✓	✓	✓
Orange	2-pipe / 2-wire	C	✓		✓		✓		✓		✓	✓		✓	✓	✓	✓
W/O plug	2-pipe reversible IFC (1)	B		✓	✓		✓		✓		✓	✓		✓	✓	✓	✓

(1) IFC : Independent Fan Control. The IFC mode signifies that the system control is only performed on the ventilation function (without valve).

(2) PBTEE : Inlet Water Low Temperature Protection (the protection cuts the ventilation function when the inlet water temperature is below 37 °C and below that of the room temperature by + 5 K).

## > Other J1 configuration block settings <

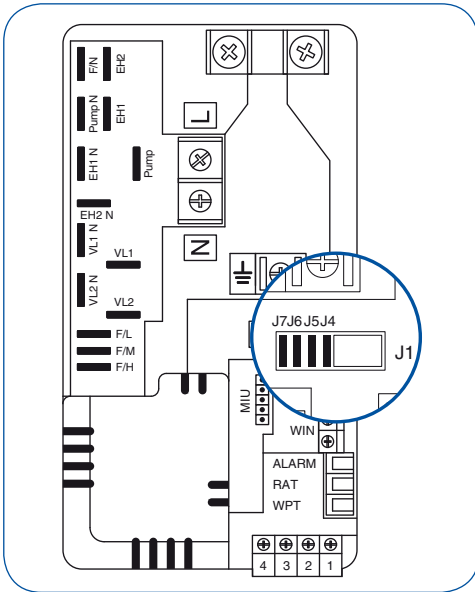

Shunt reference	Functions	Shunt presence
J4*	Use RCT only in heating mode, use RAT and RCT in cooling.	NO
J5*		YES
J4*	Use RCT only, do not use RAT.	NO
J5*		NO
J4*	Use RCT and RAT.	YES
J5*		YES
J4*	Do not use RCT. Use RAT only.	YES
J5*		NO
J6	Continuous fan operation (except when unit stopped).	YES
J7		NO
J6	Cyclical fan operation on demand in heating or cooling (no fan operation in the neutral zone).	NO
J7		YES
J6	Cyclical fan operation on demand in heating and continuous fan operation in cooling mode.	YES
J7		YES

**RCT** : RCL remote control internal sensor.

**RAT** : Fan coil unit return air sensor.

**(\*)** : Configurations managed by the 60V2 software.

**Notes :**

- 1 - The configuration J4 = YES & J5 = YES is recommended for wall mounted units.
- 2 - The configuration J4 = NO & J5 = YES is recommended for ducted and ceiling units where stratification could occur and where the sensor could be influenced by the coil temperature. Using this configuration if the RCL becomes faulty, then the RAT sensor is used.
- 3 - If more than one fan coil unit is connected to a RCL, then the RCT sensor will be used by all connected units.

## > Fan coil unit wiring <

### Master/slave hardwire network

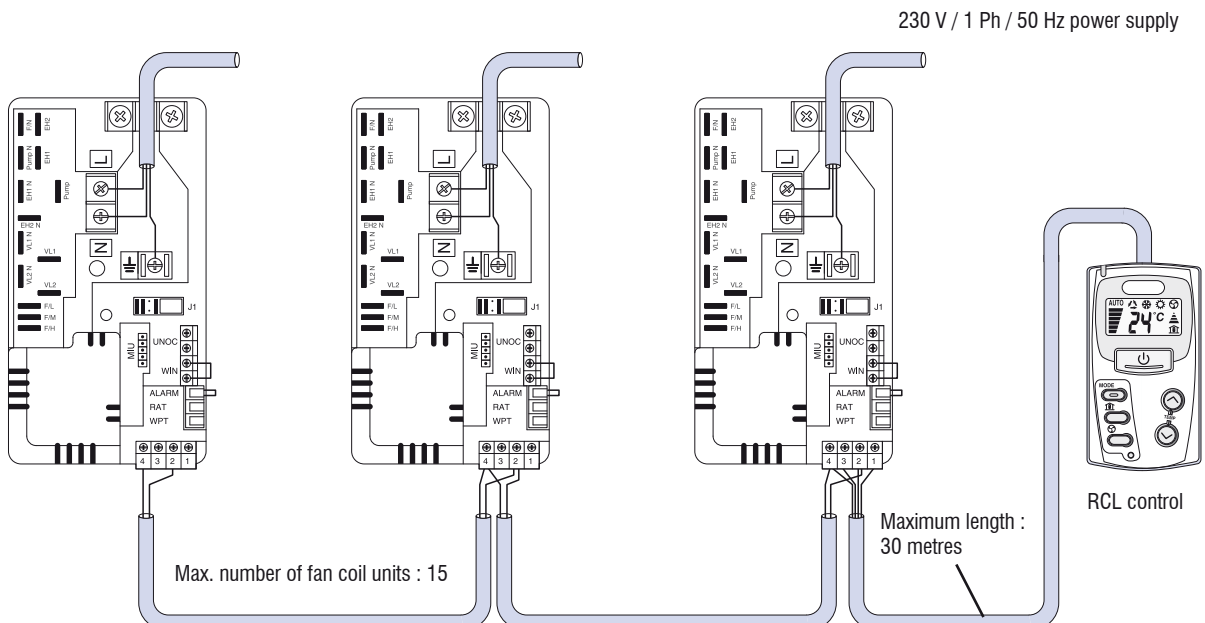

**Maximum cable length (between the RCL control and the furthest slave units) :**

**100 metres, with cable diameter between 0.4 and 0.65 mm.**

**Shielded, twisted pair cable : SYT1 AWG26 to AWG22.**

This system enables a low cost master/slave control system linking several fan coil units to be installed without the need for a communication bus and without addressing.



## > μBMS supervision station <

We have designed our new supervision station to manage system operation and temperature control of both individual and medium size heating, ventilation and air conditioning installations.

Being easy to use, it provides effective management of from 1 to 5 different temperature zones.

With the supervision station, and by way of easy to understand programming procedures, the user can alter the set temperatures for heating and cooling modes and select ventilation fan speeds in each of the controlled zones.

With the aid of a simple RS 485 communication Bus (shielded 2 twisted pair cable liaisons) the supervision station provides individual control, in each zone, of the following functions :

✓ Control and programming of ON/OFF, standby, time and day of the

week, operating modes, fan speed (LS, MS, HS, Auto) and temperature setpoints.

This programming enables time slots to be selected :

- Either individually (for each zone) over 2 time slots.
- Or globally (for all zones) over 2 time slots.
- ✓ Comfort (occupied) / economy (unoccupied) function (only with Aqu@Net) controller.
- ✓ Anti-freeze protection function in Heating mode (only with Aqu@Net controller).
- ✓ Ventilation flaps operation control function (RAC units only).

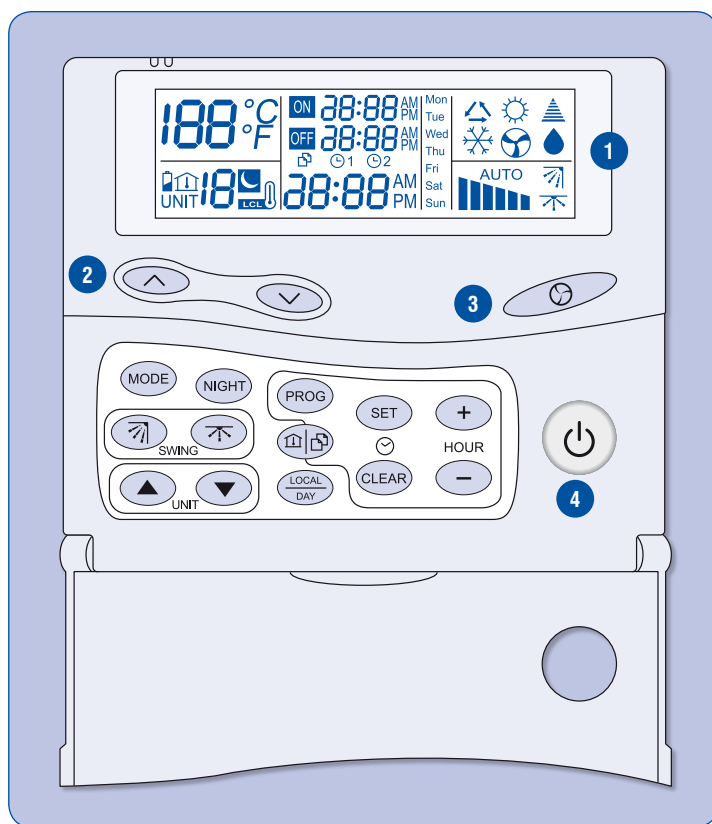

1	Display screen.
2	Keys for raising and lowering the temperature setpoint.
3	Fan mode selection :
	Low speed in forced operation.
	Medium speed in forced operation.
	High speed in forced operation.
	AUTO Automatic speed selection.
4	ON - Standby key.
(SET)	Accessing the time and day setting mode.
(+)	Advancing the time setting.
(-)	Retarding the time setting.
(CLEAR)	Clearing memory of programmed time settings in programming mode.
(LOCAL DAY)	Day of the week selection key or sending "I feel!" local temperature setting.
(PROG)	Programming mode key.
(COPY)	"Copy" key, enabling zone parameters to be duplicated for other zones.
(MODE)	Operating mode selection.
(NIGHT)	Unoccupied key for Night time slow operation.
(▲)	Current zone setting : previous zone.
(▼)	Current zone setting : next zone.
(↻)	Air sweeping : incremental or horizontal.
(↕)	Air sweeping : vertical.

## > Aqu@Net - μBMS bus architecture <

