

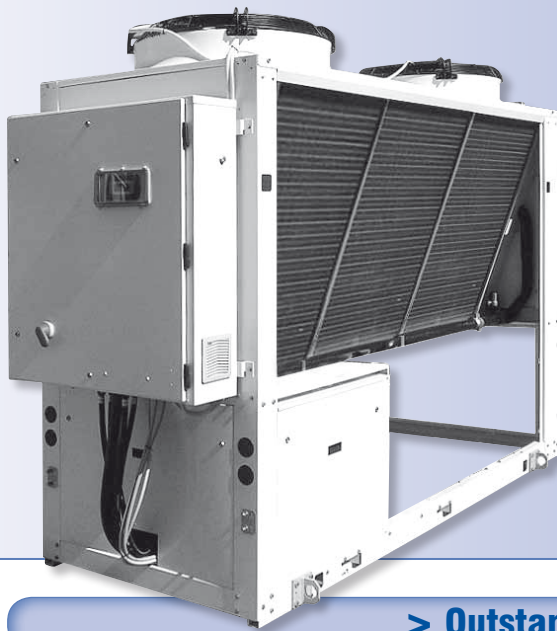

92 to 151 kW

HFC 410A



The new **Aqu@Logic AQVC** units have been designed to operate with **HFC 410A** refrigerant. Both compressors and heat exchangers have been optimized for this refrigerant.

All the units consist of **two independent refrigerant circuits** and are complete with high efficient and advanced technology components :

- Hermetic **Scroll** compressors with high efficiency and low vibration emissions,
- Quiet fans located in externally mounted **nozzle profile housing** generating low sound levels,
- Controller using a **state-of-the-art microprocessor**.

> Outstanding Strength Points <

- Units with **R410A refrigerant** (it will be the real replacement of R22). As near azeotropic mixture it behaves like a homogeneous substance (**reduced service problems in case of leakage or re-charge**) with negligible temperature glide.

Refrigerant with superior thermo-dynamical proprieties compared to R22 and R407C, it allows to have more efficiency or compact and lighter systems and larger operating limits.

- **2 independant refrigerant circuits** with 2 scroll compressors for each circuit.

- **V-shape condenser coils** ensuring compactness and small foot print.

- **2 acoustic versions** : BLN (Base Low Noise) and ELN (Extra Low Noise).

- For safety purpose when performing service operation, special valves dedicated to R410A are supplied on the refrigerant system. These valves, of 5/16" flare SAE type, are mounted on the liquid line and on the gauges manifold of the unit.

> Specifications <

General

The new **Aqu@Logic AQVC** units have been designed to operate with **HFC 410A** refrigerant. Both compressors and heat exchangers have been optimized for this refrigerant.

All the units consist of **two independent refrigerant circuits** and are complete with high efficient and advanced technology components :

- Hermetic **Scroll** compressors with high efficiency and low vibration emissions,
- Quiet fans located in externally mounted **nozzle profile housing** generating low sound levels,
- Controller using a **state-of-the-art microprocessor**.

The AQVC units are available in **6 sizes and 4 versions** :

- **STD (Standard) version** : Designed in accordance with specifications described in the following sections.
- **HSE (High Seasonal Efficiency) version** : It has same equipment as that of the STD version, except that the units are equipped with **special inverter fans**, of large diameter, driven by **EC (electronic brushless type) motors** with **integrated electronic inverter**, to ensure low energy consumption.
- **HT (High Temperature) version** : It has same equipment as HSE units, but the **special inverter fans and motors** have a different regulation.
- **HPF (High Pressure Fan) version** : It has same equipment as STD units, except that the units are equipped with **special inverter fans** (same as

those used on HSE version, but with a different regulation) driven by **EC motors** with **integrated electronic inverter**. The HPF version provides external static pressure up to **120 Pa**.

The STD and HSE versions can be supplied with **2 acoustic options** :

- **Base Low Noise (BLN)** : The units are equipped with **star or delta connected fan motors depending on size**. The chillers are not supplied with fan speed controller, but fitted with **compressors box** to reduce the noise emissions.
- **Extra Low Noise (ELN)** : The units are equipped with **star connected fan motors**, fitted with a speed controller which allows the units to operate with a very low rpm. The chillers are supplied with **compressors box** and **soundproof jackets** on compressors reducing significantly the noise emissions.

On the other hand, the HT and HPF versions can be supplied with BLN option only.

Cabinet and structure

The cabinet and structure are made of heavy gauge galvanized steel. **All galvanized steel components are individually painted** by a special painting process before the assembly of the unit. This painting system performs a homogeneous protection to the corrosion.

The painting is a polyester powder based type, coloured in **RAL 9001**.

The units are suitable for outdoor installation, directly on the building roof or at the ground level.



6 sizes with HFC 410A
2 acoustical options

 92 to 151 kW

> Specifications (continued) <

Refrigerant circuits

All the units are composed of two independent and separate refrigerant circuits, complete with 4 hermetic scroll compressors in tandem configuration for each circuit.

The units are not equipped with evaporator, but each refrigerant circuit is fitted with suction and liquid line shut-off valves to allow the connection of the unit to the external evaporator.

The functional diagram of each circuit is shown in the section "Refrigerant flow diagram".

Compressors

Each unit is equipped with 4 hermetic scroll compressors arranged in tandem configuration per refrigerant circuit.

The compressors are fitted with an electronic control device which ensures protection of compressors against :

- overheating and overloading,
- reversal rotation and phase loss.

All compressors have direct-on-line starting and are mounted on rubber vibration isolators in order to minimize noise and vibration transmission.

Condenser coils

The condenser coils are made of seamless copper tubes, arranged in staggered rows, mechanically expanded into corrugated aluminum fins.

They are mounted in V-shape arrangement, allowing the unit to be compact with small foot print.

Condenser fans

All acoustic versions (BLN & ELN) are equipped with large diameter, direct drive axial type fans with asynchronous three-phase motors.

Fans are fitted with externally mounted nozzle profile housing which generates low sound levels.

Fan speed control

The airflow is controlled in order to operate at a low ambient temperature.

On standard unit equipped with axial fans, the air flow control is :

- step type for BLN version without fan speed controls, achieved by switching off some fans of each circuit in function of condensing pressure corrected by external temperature.
- stepless type for ELN version, achieved by an electronic fan speed control, supplied as standard, in function of condensing pressure.

The pressure actuated stepless type fan speed controller can be supplied as optional on BLN version. It allows the units to operate in cooling mode at ambient temperature down to -18 °C.

Electrical board

The electrical board is located in a metal case arranged outside the unit and protected by a vertically pivoted access door. The metal case has an IP54 protection rating and is complete with grilles for natural air ventilation.

Electronic control

The units are supplied with the new microprocessor-based electronic control and management system ensuring the following functions :

→ Management of the operation of compressors :

- a) Power on/off
- b) Anticyclone management
- c) Tandem unloading for high pressure or high compressor pressure ratio (integrated inside the curves of compressor operating limits).

→ Management of high and low pressure alarms.

→ Management of external interlocks.

→ Management of the remote control :

- d) Unit power on/off
- e) Summary alarm signals

→ Remote signalling, by dry contacts :

- f) Voltage presence
- g) Compressors in operation
- h) Circuit alarm unit

The unit controller can also clearly show all control parameters of the machine on the liquid crystal display, such as :

→ Display of the ambient air temperature.

→ Display of the circuit 1 and circuit 2 discharge pressure and suction pressure.

→ Display of the set point.

→ Display of speed control signal (voltage) of fans.

→ Display of the various alarm and operation status :

- i) Compressor start-up alarm (discharge pressure check)
- j) Low / High pressure
- k) Control of the compressor operating hours
- l) Compressors in operation
- m) Thermal protection of compressors
- n) Thermal protection of fans
- o) Faulty sensors

Control and safety devices

Each unit is fitted with the following devices :

Safety :

- Power disconnect switch with an emergency stop function.
- HP switches (double on each circuit), set to 40.5 bar, automatic reset and manual reset from the control panel.
- Safety valve on the discharge line set to 45 bar.

Control :

- HP and LP transducers (two for each circuit).
- Ambient air temperature sensor.

> Specifications (continued) <

Conformity with standards

The following applies to all the sizes and versions of AQVC units :

- ✓ Machine Directive EEC 98/37 (EN ISO 12100-1/2 and EN ISO 13857-1/2)
- ✓ Low Voltage Directive EEC 2006/95 (EN 60204-1, EN 60439-1)
- ✓ Electromagnetic Compatibility Directive EEC 2004/108
- ✓ Pressure Equipment Directive 97/23/EC (EN 378-1/2)

Standard equipment

- ✓ Back light display.
- ✓ Digital pressure and temperature reading kit.
- ✓ High ambient pressure control.
- ✓ Sequence phase control.
- ✓ Control circuit transformer 400 V/230 V.
- ✓ Data logger.
- ✓ Power supply single point box.
- ✓ Power supply without neutral.
- ✓ Hour meter.
- ✓ Main switch.
- ✓ PED approval.
- ✓ Compressor jacket (ELN version only).
- ✓ Compressor box.
- ✓ Rubber anti-vibration pads.

Factory-installed options

- ✓ ModBus protocol kit for BMS.
- ✓ Lonwork protocol kit for BMS.
- ✓ Bacnet protocol kit for BMS.
- ✓ WEBctrl.
- ✓ Ethernet TCP/IP interface board.
- ✓ Compressor soft starter.
- ✓ Pressure actuated stepless fan speed controller for low ambient operation (-18 °C) (BLN version).
- ✓ Power factor correction capacitors.
- ✓ Compressor overload protection.
- ✓ Automatic circuit breaker.
- ✓ GSM.
- ✓ HP & LP manometers.
- ✓ Condenser coils with "Fin Guard Silver" (polyurethane) treatment.
- ✓ Condenser coils with copper fins.
- ✓ Condenser coils with black epoxy treatment.
- ✓ Coil guards.
- ✓ Chiller grilles.
- ✓ Compressor jacket.

Field-installed accessories

- ✓ Remote keyboard panel.
- ✓ Master and slaves control, up to 4 units max.
- ✓ Chiller grilles.



6 sizes with HFC 410A
2 acoustical options

92 to 151 kW

> Refrigerant Flow Diagram - AQC Units <

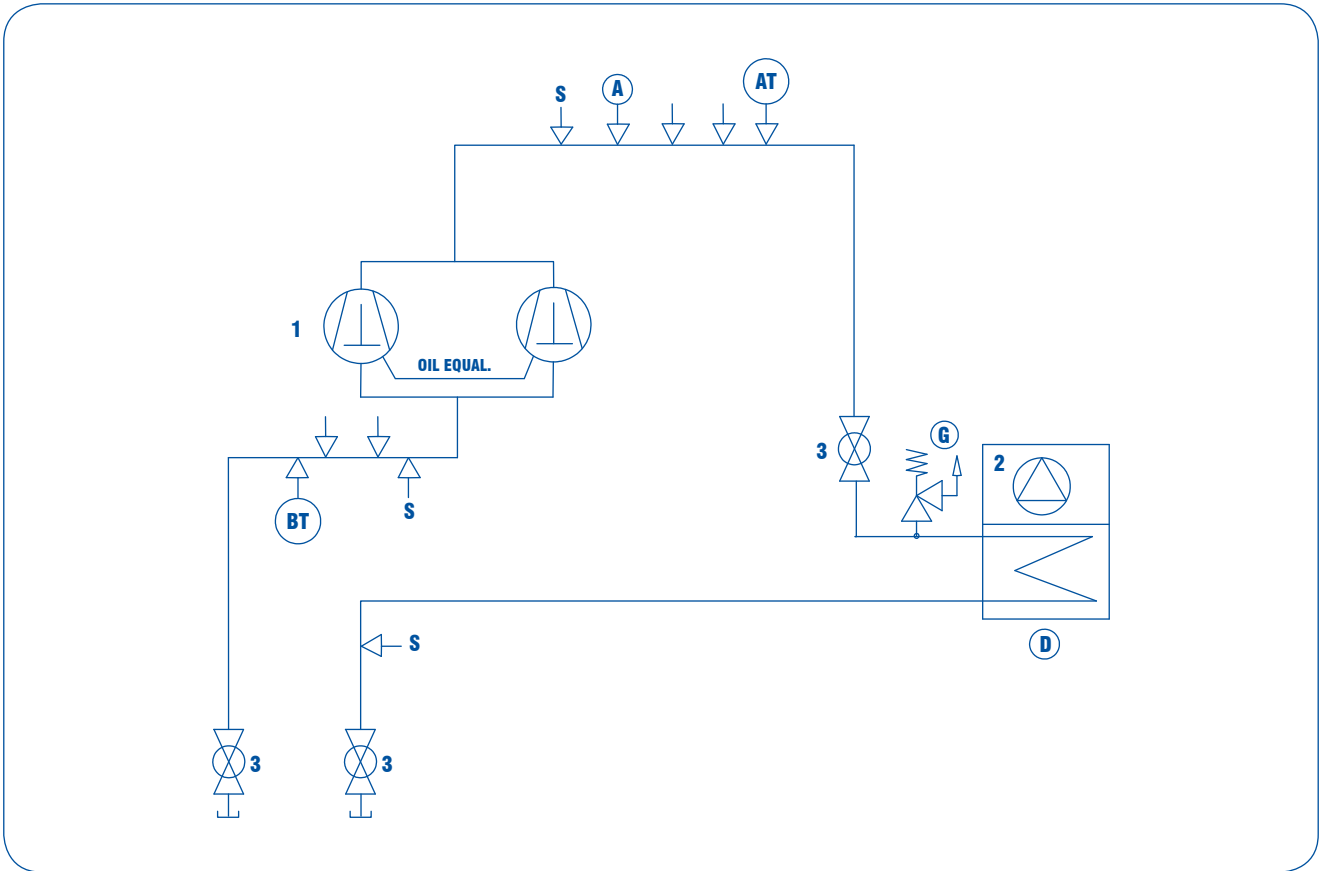

COMPONENTS	
1	Compressor tandem scroll type
2	Air cooled condenser
3	Globe valve

SAFETY / CONTROL DEVICES	
A	High pressure switch (40.5 bar)
AT	High pressure transducer
BT	Low pressure transducer
D	Air temperature sensor
G	PED pressure relief valve (45 bar)
S	5/16" schrader connection (service only)
	Pipe connection with schrader valve

Note : For reasons of readability, one circuit only is shown. The second circuit is identical.

> Operating Limits <

AQVC			85		95		105		115		125		140	
			Min.	Max.	Min.	Max.	Min.	Max.	Min.	Max.	Min.	Max.	Min.	Max.
Evaporating temperature			°C		+1 to +15									
Ambient Air	Air entering temperature	BLN	°C		0 to +48		0 to +48		0 to +48		0 to +48		0 to +48	
		ELN	°C		-18 to +45		-18 to +45		-18 to +45		-18 to +45		-18 to +45	
		HT	°C		0 to +50		0 to +50		0 to +50		0 to +50		0 to +50	
	External static pressure	Standard fans	Pa		0									
		High pressure fans	Pa		≤ 120									
Power supply voltage			400 V/ 3 Ph/ 50 Hz (nominal)											

> Correction Factors <

Fouling factors - Condenser

Fouling factor (m ² ·°C/kW)	Cooling capacity factor	Power input factor
0.044	1.000	1.000
0.088	0.987	1.023
0.176	0.955	1.068
0.352	0.910	1.135

Altitude factors

Altitude (m)	Cooling capacity factor	Power input factor
0	1.000	1.000
600	0.987	1.010
1200	0.973	1.020
1800	0.958	1.030
2400	0.943	1.040



6 sizes with HFC 410A
2 acoustical options

 92 to 151 kW

> **Technical Data - AQVC 85 to 140 - R410A - STD/HSE/HPF - BLN Version** <

AQVC Sizes - STD/HSE/HPF - BLN Version		85	95	105	115	125	140
Cooling Capacity *	kW	92.1	103.2	113.2	121.8	134.7	151.0
Input Power (Compressor)	kW	25.3	29.3	32.0	34.9	38.3	43.4
Number of Refrigerant Circuits		2	2	2	2	2	2
Part Load Steps	%	0-25-50-75-100	0-25-50-75-100	0-24-47-74-100	0-25-50-75-100	0-22-43-72-100	0-25-50-75-100
Power Supply		400V/3/50Hz	400V/3/50Hz	400V/3/50Hz	400V/3/50Hz	400V/3/50Hz	400V/3/50Hz
Startup Type		Direct	Direct	Direct	Direct	Direct	Direct
COMPRESSORS							
Number		4	4	4	4	4	4
Type		Scroll	Scroll	Scroll	Scroll	Scroll	Scroll
Crankcase Heater	W	90	90	90	90	90	90
COILS							
Number		2	2	2	2	2	2
Frontal Surface	l x a	2000 x 1200	2000 x 1200	2000 x 1200	2000 x 1200	2600 x 1200	2600 x 1200
FANS							
Number		2	2	2	2	2	2
Air Flow Rate	m ³ /h	34000	34000	33200	32400	44000	42800
Speed	rpm	690	690	690	690	900	900
Input Power	kW	2.1	2.1	2.1	2.1	3.4	3.4
REFRIGERANT CONNECTIONS							
Type		Brazed connections					
Inlet Diameter	inch	5/8"	5/8"	5/8"	5/8"	7/8"	7/8"
Outlet Diameter	inch	1"3/8	1"3/8	1"3/8	1"3/8	1"3/8	1"3/8
WEIGHT							
Shipping Weight	kg	971	983	1013	1043	1066	1142
DIMENSIONS							
Length	mm	2555	2555	2555	2555	3155	3155
Width (transport only)	mm	1095 (1250)	1095 (1250)	1095 (1250)	1095 (1250)	1095 (1250)	1095 (1250)
Height	mm	2185	2185	2185	2185	2185	2185
ACOUSTIC DATA							
Sound Power Level	dB(A)	85	85	85	85	89	89
Sound Pressure Level (1)	dB(A)	53	53	53	53	57	57

(1) Sound pressure calculated at 10 m. Sound pressure levels refer to ISO standard 3744 with parallelepiped shape.

(*) Data based on : 7 °C evaporating temperature and 35 °C condenser inlet air temperature.

> Technical Data - AQVC 85 to 140 - R410A - STD/HSE/HPF - ELN Version <

AQVC Sizes - STD/HSE/HPF - ELN Version		85	95	105	115	125	140
Cooling Capacity *	kW	89.0	99.4	108.7	116.6	131.6	147.2
Input Power (Compressor)	kW	26.8	31.3	34.3	37.5	39.8	45.2
Number of Refrigerant Circuits		2	2	2	2	2	2
Part Load Steps	%	0-25-50-75-100	0-25-50-75-100	0-24-47-74-100	0-25-50-75-100	0-22-43-72-100	0-25-50-75-100
Power Supply		400V/3/50Hz	400V/3/50Hz	400V/3/50Hz	400V/3/50Hz	400V/3/50Hz	400V/3/50Hz
Startup Type		Direct	Direct	Direct	Direct	Direct	Direct
COMPRESSORS							
Number		4	4	4	4	4	4
Type		Scroll	Scroll	Scroll	Scroll	Scroll	Scroll
Crankcase Heater	W	90	90	90	90	90	90
COILS							
Number		2	2	2	2	2	2
Frontal Surface	l x a	2000 x 1200	2000 x 1200	2000 x 1200	2000 x 1200	2600 x 1200	2600 x 1200
FANS							
Number		2	2	2	2	2	2
Air Flow Rate	m ³ /h	25200	25200	24600	24000	36500	35000
Speed	rpm	500	500	500	500	690	690
Input Power	kW	1.8	1.8	1.8	1.8	2.1	2.1
REFRIGERANT CONNECTIONS							
Type		Brazed connections					
Inlet Diameter	inch	5/8"	5/8"	5/8"	5/8"	7/8"	7/8"
Outlet Diameter	inch	1"3/8	1"3/8	1"3/8	1"3/8	1"3/8	1"3/8
WEIGHT							
Shipping Weight	kg	1001	1013	1043	1073	1096	1172
DIMENSIONS							
Length	mm	2555	2555	2555	2555	3155	3155
Width (transport only)	mm	1095 (1250)	1095 (1250)	1095 (1250)	1095 (1250)	1095 (1250)	1095 (1250)
Height	mm	2185	2185	2185	2185	2185	2185
ACOUSTIC DATA							
Sound Power Level	dB(A)	82	82	82	82	86	86
Sound Pressure Level (1)	dB(A)	50	50	50	50	54	54

(1) Sound pressure calculated at 10 m. Sound pressure levels refer to ISO standard 3744 with parallelepiped shape.

(*) Data based on : 7 °C evaporating temperature and 35 °C condenser inlet air temperature.



6 sizes with HFC 410A
2 acoustical options

 92 to 151 kW

> **Technical Data - AQVC 85 to 140 - R410A - HT** <

AQVC Sizes - HT		85	95	105	115	125	140
Cooling Capacity *	kW	95.0	106.8	117.7	127.0	137.2	153.8
Input Power (Compressor)	kW	23.9	27.4	29.8	32.3	37.1	42.1
Number of Refrigerant Circuits		2	2	2	2	2	2
Part Load Steps	%	0-25-50-75-100	0-25-50-75-100	0-24-47-74-100	0-25-50-75-100	0-22-43-72-100	0-25-50-75-100
Power Supply		400V/3/50Hz	400V/3/50Hz	400V/3/50Hz	400V/3/50Hz	400V/3/50Hz	400V/3/50Hz
Startup Type		Direct	Direct	Direct	Direct	Direct	Direct
COMPRESSORS							
Number		4	4	4	4	4	4
Type		Scroll	Scroll	Scroll	Scroll	Scroll	Scroll
Crankcase Heater	W	90	90	90	90	90	90
COILS							
Number		2	2	2	2	2	2
Frontal Surface	l x a	2000 x 1200	2000 x 1200	2000 x 1200	2000 x 1200	2600 x 1200	2600 x 1200
FANS							
Number		2	2	2	2	2	2
Air Flow Rate	m ³ /h	49700	49700	48950	48200	52200	50700
Speed	rpm	1130	1130	1130	1130	1130	1130
Input Power	kW	4.6	4.6	4.6	4.6	4.6	4.6
REFRIGERANT CONNECTIONS							
Type		Brazed connections					
Inlet Diameter	inch	5/8"	5/8"	5/8"	5/8"	7/8"	7/8"
Outlet Diameter	inch	1"3/8	1"3/8	1"3/8	1"3/8	1"3/8	1"3/8
WEIGHT							
Shipping Weight	kg	971	983	1013	1043	1066	1142
DIMENSIONS							
Length	mm	2555	2555	2555	2555	3155	3155
Width (transport only)	mm	1095 (1250)	1095 (1250)	1095 (1250)	1095 (1250)	1095 (1250)	1095 (1250)
Height	mm	2185	2185	2185	2185	2185	2185
ACOUSTIC DATA							
Sound Power Level	dB(A)	95	95	95	95	95	95
Sound Pressure Level (1)	dB(A)	63	63	63	63	63	63

(1) Sound pressure calculated at 10 m. Sound pressure levels refer to ISO standard 3744 with parallepiped shape.

(*) Data based on : 7 °C evaporating temperature and 35 °C condenser inlet air temperature.

> Electrical Data - AQVC 85 to 140 - R410A - STD Units <

Compressor data - 400 V/3Ph/50Hz

			NOMINAL		MAX		Istartup LRA (A)	Power factor coefficient (NOM)
			Pnom (kW)	Inom (A)	Pmax (kW)	I _{max} FLA (A)		
AQVC 85	Circuit 1	COMP 1	6.3	11.3	9.1	16	95	0.8
		COMP 2	6.3	11.3	9.1	16	95	0.8
	Circuit 2	COMP 1	6.3	11.3	9.1	16	95	0.8
		COMP 2	6.3	11.3	9.1	16	95	0.8
AQVC 95	Circuit 1	COMP 1	7.1	12.7	10.2	21	111	0.8
		COMP 2	7.1	12.7	10.2	21	111	0.8
	Circuit 2	COMP 1	7.1	12.7	10.2	21	111	0.8
		COMP 2	7.1	12.7	10.2	21	111	0.8
AQVC 105	Circuit 1	COMP 1	8.3	15.3	12.0	22	118	0.8
		COMP 2	8.3	15.3	12.0	22	118	0.8
	Circuit 2	COMP 1	7.1	12.7	10.2	21	111	0.8
		COMP 2	7.1	12.7	10.2	21	111	0.8
AQVC 115	Circuit 1	COMP 1	8.3	15.3	12.0	22	118	0.8
		COMP 2	8.3	15.3	12.0	22	118	0.8
	Circuit 2	COMP 1	8.3	15.3	12.0	22	118	0.8
		COMP 2	8.3	15.3	12.0	22	118	0.8
AQVC 125	Circuit 1	COMP 1	10.5	19.1	14.8	31	140	0.8
		COMP 2	8.3	15.3	12.0	22	118	0.8
	Circuit 2	COMP 1	10.5	19.1	14.8	31	140	0.8
		COMP 2	8.3	15.3	12.0	22	118	0.8
AQVC 140	Circuit 1	COMP 1	10.5	19.1	14.8	31	140	0.8
		COMP 2	10.5	19.1	14.8	31	140	0.8
	Circuit 2	COMP 1	10.5	19.1	14.8	31	140	0.8
		COMP 2	10.5	19.1	14.8	31	140	0.8

Fan data - 400 V/3Ph/50Hz - BLN Version

Sizes	Number of fans	Pmax per fan (kW)	I _{max} per fan FLA(A)	Total fan power (kW)	Total fan max. current (A)
AQVC 85	2	1.2	2.2	2.4	4.5
AQVC 95	2	1.2	2.2	2.4	4.5
AQVC 105	2	1.2	2.2	2.4	4.5
AQVC 115	2	1.2	2.2	2.4	4.5
AQVC 125	2	1.9	3.9	3.9	7.8
AQVC 140	2	1.9	3.9	3.9	7.8

Fan data - 400 V/3Ph/50Hz - ELN Version

Sizes	Number of fans	Pmax per fan (kW)	I _{max} per fan FLA(A)	Total fan power (kW)	Total fan max. current (A)
AQVC 85	2	1.2	2.2	2.4	4.5
AQVC 95	2	1.2	2.2	2.4	4.5
AQVC 105	2	1.2	2.2	2.4	4.5
AQVC 115	2	1.2	2.2	2.4	4.5
AQVC 125	2	1.2	2.2	2.4	4.5
AQVC 140	2	1.2	2.2	2.4	4.5



6 sizes with HFC 410A
2 acoustical options

 92 to 151 kW

> **Electrical Data - AQVC 85 to 140 - R410A - STD Units (cont'd)** <

Units - 400 V/3Ph/50Hz - BLN Version

Sizes		AQVC 85	AQVC 95	AQVC 105	AQVC 115	AQVC 125	AQVC 140
Power input (kW)	Nominal	27.4	30.6	33.1	35.5	41.4	45.9
	Maximum	38.8	43.2	46.7	50.2	57.3	62.9
Current input (A)	Nominal	49.8	55.3	60.4	65.5	76.5	84.2
	Maximum	68.5	88.5	90.5	92.5	113.8	131.8
Start-up current (A)		147.5	178.5	186.5	188.5	223	241

Units - 400 V/3Ph/50Hz - ELN Version

Sizes		AQVC 85	AQVC 95	AQVC 105	AQVC 115	AQVC 125	AQVC 140
Power input (kW)	Nominal	27.4	30.6	33.1	35.5	40.0	44.4
	Maximum	38.8	43.2	46.7	50.2	55.8	61.4
Current input (A)	Nominal	49.8	55.3	60.4	65.5	73.2	80.9
	Maximum	68.5	88.5	90.5	92.5	110.5	128.5
Start-up current (A)		147	178	186	188	219	237

> Electrical Data - AQVC 85 to 140 - R410A - HSE/HPF/HT Units <

Compressor data - 400 V/3Ph/50Hz

			NOMINAL		MAX		Istartup LRA (A)	Power factor coefficient (NOM)
			Pnom (kW)	Inom (A)	Pmax (kW)	Imax FLA (A)		
AQVC 85	Circuit 1	COMP 1	6.3	11.3	9.1	16	95	0.8
		COMP 2	6.3	11.3	9.1	16	95	0.8
	Circuit 2	COMP 1	6.3	11.3	9.1	16	95	0.8
		COMP 2	6.3	11.3	9.1	16	95	0.8
AQVC 95	Circuit 1	COMP 1	7.1	12.7	10.2	21	111	0.8
		COMP 2	7.1	12.7	10.2	21	111	0.8
	Circuit 2	COMP 1	7.1	12.7	10.2	21	111	0.8
		COMP 2	7.1	12.7	10.2	21	111	0.8
AQVC 105	Circuit 1	COMP 1	8.3	15.3	12.0	22	118	0.8
		COMP 2	8.3	15.3	12.0	22	118	0.8
	Circuit 2	COMP 1	7.1	12.7	10.2	21	111	0.8
		COMP 2	7.1	12.7	10.2	21	111	0.8
AQVC 115	Circuit 1	COMP 1	8.3	15.3	12.0	22	118	0.8
		COMP 2	8.3	15.3	12.0	22	118	0.8
	Circuit 2	COMP 1	8.3	15.3	12.0	22	118	0.8
		COMP 2	8.3	15.3	12.0	22	118	0.8
AQVC 125	Circuit 1	COMP 1	10.5	19.1	14.8	31	140	0.8
		COMP 2	8.3	15.3	12.0	22	118	0.8
	Circuit 2	COMP 1	10.5	19.1	14.8	31	140	0.8
		COMP 2	8.3	15.3	12.0	22	118	0.8
AQVC 140	Circuit 1	COMP 1	10.5	19.1	14.8	31	140	0.8
		COMP 2	10.5	19.1	14.8	31	140	0.8
	Circuit 2	COMP 1	10.5	19.1	14.8	31	140	0.8
		COMP 2	10.5	19.1	14.8	31	140	0.8

Fan data - 400 V/3Ph/50Hz

Sizes	Number of fans	Pmax per fan (kW)	Imax per fan FLA(A)	Total fan power (kW)	Total fan max. current (A)
AQVC 85	2	2.8	4.5	5.6	9.0
AQVC 95	2	2.8	4.5	5.6	9.0
AQVC 105	2	2.8	4.5	5.6	9.0
AQVC 115	2	2.8	4.5	5.6	9.0
AQVC 125	2	2.8	4.5	5.6	9.0
AQVC 140	2	2.8	4.5	5.6	9.0

Units - 400 V/3Ph/50Hz

Sizes		AQVC 85	AQVC 95	AQVC 105	AQVC 115	AQVC 125	AQVC 140
Power input (kW)	Nominal	30.6	33.8	36.2	38.7	43.1	47.6
	Maximum	42.0	46.4	49.9	53.4	59.0	64.6
Current input (A)	Nominal	54.3	59.8	65.0	70.1	77.7	85.4
	Maximum	73.0	93.0	95.0	97.0	115.0	133.0
Start-up current (A)		152	183	191	193	224	242



6 sizes with HFC 410A
2 acoustical options

 92 to 151 kW

> HPF Version Fan Performance Data <

AQVL/AQVH Sizes	Fan Static Pressure (Pa)	Fan RPM	Parameter in Service Level Max Speed (Vdc)	Sound Power Level dB(A)
85	40	880	8.2	88
	60	920	8.5	89
	80	950	8.7	90
	100	990	9.0	91
	120	1030	9.3	92
95	40	880	8.2	88
	60	920	8.5	89
	80	950	8.7	90
	100	990	9.0	91
	120	1030	9.3	92
105	40	870	8.1	88
	60	910	8.4	89
	80	950	8.7	90
	100	990	9.0	91
	120	1030	9.3	92
115	40	870	8.1	88
	60	910	8.4	89
	80	950	8.7	90
	100	990	9.0	91
	120	1030	9.3	92
125	40	1000	9.1	91
	60	1030	9.3	92
	80	1070	9.6	93
	100	1100	9.8	94
	120	1130	10.0	95
140	40	1000	9.1	91
	60	1030	9.3	92
	80	1060	9.5	93
	100	1090	9.7	94
	120	1130	10.0	95

> Sound Data <

STD/HSE BLN Versions

Sizes	Octave Band (Hz)								Sound Power Level dB(A)	Sound Pressure Level* dB(A)
	63	125	250	500	1000	2000	4000	8000		
85	98	91	86	82	81	74	69	69	85	53
95	98	91	86	82	81	74	69	69	85	53
105	98	91	86	82	81	74	69	69	85	53
115	98	91	86	82	81	74	69	69	85	53
125	102	95	89	86	84	78	72	72	89	57
140	102	95	89	86	84	78	72	72	89	57

STD/HSE ELN Versions

Sizes	Octave Band (Hz)								Sound Power Level dB(A)	Sound Pressure Level* dB(A)
	63	125	250	500	1000	2000	4000	8000		
85	94	87	82	79	77	71	67	66	82	50
95	94	87	82	79	77	71	67	66	82	50
105	94	87	82	79	77	71	67	66	82	50
115	94	87	82	79	77	71	67	66	82	50
125	99	92	86	83	81	75	70	70	86	54
140	99	92	86	83	81	75	70	70	86	54

HPF

Sizes	Octave Band (Hz)								Sound Power Level dB(A)	Sound Pressure Level * dB(A)
	63	125	250	500	1000	2000	4000	8000		
85	109	102	96	92	90	83	77	77	95	63
95	109	102	96	92	90	83	77	77	95	63
105	109	102	96	92	90	83	77	77	95	63
115	109	102	96	92	90	83	77	77	95	63
125	109	102	96	92	90	83	77	77	95	63
140	109	102	96	92	90	83	77	77	95	63

HT **

Sizes	Octave Band (Hz)								Sound Power Level dB(A)	Sound Pressure Level * dB(A)
	63	125	250	500	1000	2000	4000	8000		
85	106	99	93	89	87	80	75	75	92	60
95	106	99	93	89	87	80	75	75	92	60
105	106	99	93	89	87	80	75	75	92	60
115	106	99	93	89	87	80	75	75	92	60
125	109	102	96	92	90	83	77	77	95	63
140	109	102	96	92	90	83	77	77	95	63

(*) Sound pressure at 10 m, data refer to ISO standard 3744 with parallelepiped shape.

(**) Sound data valid in max. air flow rate/max. fan RPM condition.



6 sizes with HFC 410A
2 acoustical options

92 to 151 kW

> Performance Data - AQVC 85 to 140 - R410A - STD/HSE/HPF - BLN Version <

AQVC Sizes BLN Version	Temp. evap. (°C)	Outdoor air temperature (°C)																	
		25		30		32		35		38		40		42		45		48	
		P cool (kW)	P abs* (kW)	P cool (kW)	P abs* (kW)	P cool (kW)	P abs* (kW)	P cool (kW)	P abs* (kW)	P cool (kW)	P abs* (kW)	P cool (kW)	P abs* (kW)	P cool (kW)	P abs* (kW)	P cool (kW)	P abs* (kW)	P cool (kW)	P abs* (kW)
AQVC 85	1	87.3	19.8	83.3	21.9	81.7	22.8	79.1	24.2	76.1	25.6	73.9	26.6	71.7	27.7	68.3	29.4	65.0	31.0
	3	92.3	20.2	88.0	22.2	86.3	23.2	83.6	24.6	80.4	26.0	78.2	27.0	75.9	28.1	72.4	29.7		
	5	96.6	20.5	92.2	22.6	90.5	23.5	87.7	24.9	84.5	26.4	82.2	27.4	79.8	28.4	76.3	30.1		
	7	101.4	20.9	96.8	23.0	95.0	23.9	92.1	25.3	88.7	26.8	86.4	27.8	83.9	28.8	80.3	30.4		
	9	106.6	21.3	101.8	23.4	99.9	24.3	96.9	25.7	93.4	27.2	90.9	28.2	88.5	29.3				
	11	112.3	21.8	107.2	23.9	105.2	24.9	102.1	26.3	98.5	27.7	95.9	28.7	93.2	29.8				
	14	121.4	22.8	115.8	24.9	113.6	25.8	109.9	27.2	105.3	28.5	102.1	29.4	98.8	30.4				
AQVC 95	1	97.9	22.9	93.3	25.3	91.5	26.3	88.6	28.0	85.3	29.7	82.8	30.8	80.4	32.1	76.6	34.0	72.8	35.9
	3	103.4	23.3	98.7	25.8	96.8	26.8	93.7	28.5	90.2	30.1	87.7	31.3	85.1	32.5	81.2	34.4		
	5	108.3	23.7	103.4	26.1	101.4	27.2	98.3	28.8	94.7	30.5	92.1	31.7	89.5	32.9	85.5	34.8		
	7	113.7	24.2	108.5	26.6	106.5	27.6	103.2	29.3	99.5	31.0	96.8	32.1	94.1	33.4	90.0	35.3		
	9	119.4	24.7	114.1	27.1	112.0	28.2	108.6	29.8	104.7	31.5	101.9	32.7	99.2	33.9				
	11	125.9	25.3	120.2	27.7	118.0	28.8	114.4	30.4	110.4	32.1	107.5	33.3	104.5	34.4				
	14	136.0	26.4	129.8	28.8	127.3	29.8	123.2	31.4	118.1	33.0	114.4	34.1	110.8	35.2				
AQVC 105	1	107.4	25.0	102.4	27.6	100.4	28.8	97.2	30.5	93.5	32.4	90.9	33.7	88.2	35.0	84.0	37.1	79.9	39.2
	3	113.5	25.5	108.2	28.1	106.2	29.3	102.8	31.1	98.9	32.9	96.2	34.2	93.3	35.5	89.0	37.6		
	5	118.8	25.9	113.4	28.5	111.3	29.7	107.8	31.5	103.9	33.3	101.0	34.6	98.1	35.9	93.8	38.0		
	7	124.7	26.4	119.0	29.0	116.8	30.2	113.2	32.0	109.1	33.8	106.2	35.1	103.2	36.4	98.8	38.5		
	9	131.0	26.9	125.1	29.6	122.8	30.7	119.1	32.5	114.8	34.4	111.8	35.6	108.9	37.0				
	11	138.1	27.6	131.9	30.2	129.4	31.4	125.5	33.2	121.1	35.0	117.9	36.3	114.6	37.6				
	14	149.2	28.8	142.4	31.4	139.7	32.6	135.1	34.3	129.5	36.0	125.5	37.2	121.5	38.4				
AQVC 115	1	115.6	27.2	110.2	30.1	108.0	31.4	104.6	33.3	100.6	35.3	97.8	36.7	94.8	38.2	90.4	40.5	86.0	42.8
	3	122.1	27.8	116.5	30.7	114.2	31.9	110.6	33.9	106.4	35.9	103.5	37.3	100.4	38.7	95.8	41.0		
	5	127.9	28.2	122.0	31.1	119.7	32.4	116.0	34.3	111.8	36.3	108.7	37.7	105.6	39.2	100.9	41.4		
	7	134.2	28.7	128.1	31.6	125.7	32.9	121.8	34.9	117.4	36.9	114.3	38.3	111.1	39.7	106.3	42.0		
	9	141.0	29.4	134.6	32.3	132.2	33.5	128.2	35.5	123.6	37.5	120.3	38.9	117.1	40.3				
	11	148.6	30.1	141.9	33.0	139.2	34.3	135.1	36.2	130.3	38.2	126.9	39.6	123.3	41.0				
	14	160.6	31.4	153.3	34.3	150.3	35.5	145.4	37.4	139.4	39.3	135.0	40.6	130.7	41.9				
AQVC 125	1	127.8	29.9	121.8	33.1	119.5	34.4	115.7	36.6	111.3	38.8	108.1	40.3	104.9	41.9	100.0	44.4	95.0	47.0
	3	135.0	30.5	128.8	33.7	126.3	35.0	122.3	37.2	117.7	39.4	114.4	40.9	111.0	42.5	105.9	45.0		
	5	141.4	31.0	134.9	34.2	132.4	35.5	128.3	37.7	123.6	39.9	120.2	41.4	116.7	43.0	111.6	45.5		
	7	148.3	31.6	141.6	34.7	138.9	36.1	134.7	38.3	129.8	40.5	126.3	42.0	122.8	43.6	117.5	46.1		
	9	155.9	32.3	148.9	35.4	146.1	36.8	141.7	39.0	136.6	41.2	133.0	42.7	129.5	44.3				
	11	164.3	33.1	156.9	36.2	153.9	37.6	149.3	39.8	144.1	42.0	140.3	43.5	136.4	45.0				
	14	177.5	34.5	169.4	37.7	166.2	39.0	160.7	41.1	154.1	43.2	149.3	44.6	144.5	46.0				
AQVC 140	1	143.3	33.9	136.6	37.5	134.0	39.0	129.7	41.4	124.8	43.9	121.2	45.7	117.6	47.5	112.1	50.3	106.6	53.2
	3	151.4	34.6	144.4	38.1	141.6	39.7	137.1	42.1	132.0	44.6	128.3	46.3	124.5	48.2	118.8	51.0		
	5	158.5	35.1	151.3	38.7	148.5	40.3	143.9	42.7	138.6	45.2	134.8	46.9	130.9	48.7	125.1	51.5		
	7	166.4	35.8	158.8	39.3	155.8	40.9	151.0	43.4	145.6	45.9	141.7	47.6	137.7	49.4	131.7	52.2		
	9	174.8	36.5	166.9	40.1	163.9	41.7	158.9	44.1	153.2	46.6	149.2	48.3	145.2	50.2				
	11	184.2	37.4	175.9	41.0	172.6	42.6	167.5	45.1	161.6	47.5	157.3	49.2	152.9	51.0				
	14	199.1	39.0	190.0	42.6	186.4	44.2	180.2	46.5	172.8	48.9	167.4	50.5	162.1	52.1				

(*) Compressors only

> Performance Data - AQVC 85 to 140 - R410A - STD/HSE - ELN Version <

AQVC Sizes ELN Version	Temp. evap. (°C)	Outdoor air temperature (°C)															
		25		30		32		35		38		40		42		45	
		P cool (kW)	P abs* (kW)	P cool (kW)	P abs* (kW)	P cool (kW)	P abs* (kW)	P cool (kW)	P abs* (kW)	P cool (kW)	P abs* (kW)	P cool (kW)	P abs* (kW)	P cool (kW)	P abs* (kW)	P cool (kW)	P abs* (kW)
AQVC 85	1	84.5	20.9	80.5	23.1	79.0	24.1	76.5	25.6	73.6	27.1	71.5	28.2	69.3	29.3	66.1	31.1
	3	89.3	21.4	85.1	23.6	83.5	24.5	80.9	26.0	77.8	27.6	75.6	28.6	73.4	29.8		
	5	93.5	21.7	89.2	23.9	87.5	24.9	84.8	26.4	81.7	27.9	79.5	29.0	77.2	30.1		
	7	98.1	22.1	93.6	24.3	91.9	25.3	89.0	26.8	85.8	28.3	83.5	29.4				
	9	103.1	22.6	98.4	24.8	96.6	25.8	93.7	27.3	90.3	28.8	88.0	29.9				
	11	108.6	23.1	103.7	25.4	101.8	26.3	98.7	27.8	95.3	29.4						
	14	117.4	24.1	112.0	26.3	109.9	27.3	106.3	28.8	101.9	30.2						
AQVC 95	1	94.4	24.4	90.0	27.0	88.2	28.1	85.4	29.9	82.2	31.7	79.8	33.0	77.4	34.3	73.8	36.3
	3	99.7	24.9	95.1	27.5	93.3	28.6	90.3	30.4	86.9	32.2	84.5	33.4	82.0	34.8		
	5	104.4	25.4	99.6	27.9	97.8	29.0	94.7	30.8	91.2	32.6	88.8	33.9	86.2	35.2		
	7	109.5	25.8	104.6	28.4	102.6	29.5	99.4	31.3	95.9	33.1	93.3	34.3				
	9	115.1	26.4	109.9	29.0	107.9	30.1	104.7	31.8	100.9	33.6	98.2	34.9				
	11	121.3	27.0	115.8	29.6	113.7	30.7	110.3	32.5	106.4	34.3						
	14	131.1	28.2	125.1	30.8	122.7	31.9	118.7	33.6	113.8	35.3						
AQVC 105	1	103.1	26.8	98.3	29.6	96.4	30.8	93.3	32.8	89.8	34.7	87.2	36.1	84.6	37.5	80.7	39.8
	3	108.9	27.3	103.9	30.1	101.9	31.4	98.7	33.3	95.0	35.3	92.3	36.6	89.6	38.1		
	5	114.1	27.8	108.9	30.6	106.8	31.8	103.5	33.8	99.7	35.7	97.0	37.1	94.2	38.5		
	7	119.7	28.3	114.3	31.1	112.1	32.3	108.7	34.3	104.7	36.3	101.9	37.6				
	9	125.8	28.9	120.1	31.7	117.9	33.0	114.4	34.9	110.2	36.9	107.3	38.2				
	11	132.5	29.6	126.6	32.4	124.2	33.7	120.5	35.6	116.3	37.6						
	14	143.2	30.8	136.7	33.7	134.1	34.9	129.7	36.8	124.3	38.6						
AQVC 115	1	110.6	29.3	105.4	32.4	103.4	33.7	100.1	35.8	96.3	38.0	93.6	39.5	90.8	41.1	86.5	43.5
	3	116.8	29.9	111.4	33.0	109.3	34.3	105.8	36.4	101.9	38.6	99.0	40.1	96.1	41.7		
	5	122.3	30.4	116.8	33.5	114.6	34.8	111.0	36.9	106.9	39.1	104.0	40.6	101.0	42.1		
	7	128.4	30.9	122.6	34.0	120.2	35.4	116.6	37.5	112.3	39.7	109.3	41.2				
	9	134.9	31.6	128.8	34.7	126.5	36.1	122.7	38.2	118.2	40.3	115.1	41.8				
	11	142.2	32.4	135.8	35.5	133.2	36.9	129.2	39.0	124.7	41.1						
	14	153.7	33.7	146.6	36.9	143.8	38.2	139.1	40.3	133.4	42.3						
AQVC 125	1	124.8	31.1	119.0	34.3	116.7	35.8	113.0	38.0	108.7	40.3	105.6	41.9	102.5	43.5	97.7	46.1
	3	131.9	31.7	125.8	34.9	123.4	36.4	119.5	38.6	115.0	40.9	111.8	42.5	108.5	44.1		
	5	138.1	32.2	131.8	35.5	129.3	36.9	125.3	39.1	120.7	41.4	117.4	43.0	114.1	44.7		
	7	144.9	32.8	138.4	36.1	135.7	37.5	131.6	39.8	126.8	42.0	123.4	43.6				
	9	152.3	33.5	145.4	36.8	142.8	38.2	138.5	40.4	133.5	42.7	130.0	44.3				
	11	160.5	34.3	153.3	37.6	150.4	39.1	145.9	41.3	140.8	43.6						
	14	173.5	35.8	165.5	39.1	162.4	40.5	157.0	42.7	150.5	44.8						
AQVC 140	1	139.6	35.3	133.1	39.0	130.6	40.7	126.4	43.2	121.6	45.8	118.1	47.6	114.6	49.5	109.2	52.5
	3	147.5	36.0	140.7	39.7	138.0	41.4	133.6	43.9	128.6	46.5	125.0	48.3	121.4	50.2		
	5	154.5	36.6	147.5	40.3	144.7	42.0	140.2	44.5	135.0	47.1	131.4	48.9	127.6	50.8		
	7	162.1	37.3	154.8	41.0	151.8	42.6	147.2	45.2	141.9	47.8	138.1	49.6				
	9	170.4	38.1	162.7	41.8	159.7	43.4	154.9	46.0	149.3	48.6	145.4	50.4				
	11	179.5	39.0	171.4	42.8	168.3	44.4	163.2	47.0	157.5	49.6						
	14	194.0	40.7	185.2	44.4	181.6	46.1	175.7	48.5	168.4	50.9						

(*) Compressors only



6 sizes with HFC 410A
2 acoustical options

92 to 151 kW

> Performance Data - AQVC 85 to 140 - R410A - HT <

AQVC Sizes HT Version	Temp. evap. (°C)	Outdoor air temperature (°C)																			
		25		30		32		35		38		40		42		45		48		50	
		P cool (kW)	P abs* (kW)	P cool (kW)	P abs* (kW)	P cool (kW)	P abs* (kW)	P cool (kW)	P abs* (kW)	P cool (kW)	P abs* (kW)	P cool (kW)	P abs* (kW)	P cool (kW)	P abs* (kW)	P cool (kW)	P abs* (kW)	P cool (kW)	P abs* (kW)	P cool (kW)	P abs* (kW)
AQVC 85	1	90.1	18.7	85.9	20.7	84.2	21.5	81.6	22.8	78.5	24.2	76.2	25.2	74.0	26.2	70.5	27.8	67.0	29.3	64.8	30.3
	3	95.2	19.1	90.8	21.0	89.1	21.9	86.2	23.2	83.0	24.6	80.7	25.6	78.3	26.6	74.7	28.1	71.1	29.7	68.7	30.7
	5	99.7	19.4	95.2	21.3	93.4	22.2	90.5	23.5	87.1	24.9	84.8	25.9	82.3	26.9	78.7	28.4	75.0	30.0		
	7	104.6	19.7	99.9	21.7	98.0	22.6	95.0	23.9	91.5	25.3	89.1	26.2	86.6	27.2	82.9	28.8	79.1	30.3		
	9	110.0	20.1	105.0	22.1	103.1	23.0	100.0	24.3	96.4	25.7	93.8	26.7	91.3	27.7	87.7	29.2				
	11	115.9	20.6	110.6	22.6	108.6	23.5	105.3	24.8	101.6	26.2	99.0	27.1	96.2	28.1	91.9	29.6				
	14	125.2	21.5	119.5	23.5	117.2	24.4	113.4	25.7	108.7	26.9	105.3	27.8	101.9	28.7	97.0	30.2				
AQVC 95	1	101.3	21.4	96.6	23.7	94.7	24.7	91.7	26.2	88.2	27.8	85.7	28.9	83.2	30.0	79.3	31.8	75.4	33.6	72.8	34.8
	3	107.1	21.9	102.1	24.1	100.1	25.1	97.0	26.6	93.3	28.2	90.7	29.3	88.1	30.5	84.0	32.3	80.0	34.0	77.3	35.2
	5	112.1	22.2	107.0	24.5	105.0	25.5	101.7	27.0	98.0	28.6	95.3	29.7	92.6	30.8	88.5	32.6	84.4	34.4		
	7	117.6	22.6	112.3	24.9	110.2	25.9	106.8	27.4	102.9	29.0	100.2	30.1	97.4	31.2	93.2	33.0	88.9	34.8		
	9	123.6	23.1	118.0	25.4	115.9	26.4	112.4	27.9	108.3	29.5	105.5	30.6	102.7	31.7	98.6	33.5				
	11	130.3	23.7	124.4	26.0	122.1	27.0	118.4	28.5	114.3	30.1	111.3	31.1	108.1	32.3	103.3	34.0				
	14	140.8	24.7	134.4	27.0	131.8	28.0	127.5	29.4	122.2	30.9	118.4	31.9	114.6	33.0	109.0	34.6				
AQVC 105	1	111.7	23.3	106.5	25.7	104.4	26.8	101.1	28.4	97.2	30.1	94.5	31.3	91.6	32.6	87.4	34.5	83.1	36.5	80.2	37.8
	3	118.0	23.7	112.5	26.2	110.4	27.2	106.9	28.9	102.9	30.6	100.0	31.8	97.0	33.1	92.6	35.0	88.1	36.9	85.2	38.2
	5	123.5	24.1	117.9	26.6	115.7	27.6	112.1	29.3	108.0	31.0	105.0	32.2	102.0	33.4	97.5	35.4	93.0	37.3		
	7	129.6	24.5	123.8	27.0	121.4	28.1	117.7	29.8	113.4	31.5	110.4	32.7	107.3	33.9	102.7	35.8	98.0	37.7		
	9	136.2	25.1	130.1	27.5	127.7	28.6	123.9	30.3	119.4	32.0	116.3	33.2	113.2	34.4	108.6	36.4				
	11	143.6	25.7	137.1	28.2	134.5	29.2	130.5	30.9	125.9	32.6	122.6	33.8	119.2	35.0	113.8	36.9				
	14	155.1	26.8	148.1	29.3	145.2	30.3	140.5	31.9	134.7	33.5	130.5	34.6	126.3	35.8	120.1	37.5				
AQVC 115	1	120.5	25.2	114.9	27.9	112.7	29.1	109.1	30.9	104.9	32.7	102.0	34.0	98.9	35.4	94.3	37.5	89.6	39.6	86.6	41.0
	3	127.3	25.8	121.4	28.4	119.1	29.6	115.3	31.4	111.0	33.2	107.9	34.5	104.7	35.9	99.9	38.0	95.1	40.1	91.9	41.5
	5	133.3	26.2	127.3	28.8	124.9	30.0	121.0	31.8	116.5	33.7	113.4	35.0	110.1	36.3	105.2	38.4	100.3	40.5		
	7	139.9	26.6	133.6	29.3	131.0	30.5	127.0	32.3	122.4	34.2	119.2	35.5	115.8	36.8	110.8	38.9	105.8	41.0		
	9	147.0	27.2	140.4	29.9	137.8	31.1	133.7	32.9	128.9	34.7	125.5	36.0	122.1	37.4	117.2	39.5				
	11	154.9	27.9	148.0	30.6	145.2	31.7	140.8	33.6	135.9	35.4	132.3	36.7	128.6	38.0	122.9	40.0				
	14	167.4	29.1	159.8	31.8	156.7	32.9	151.6	34.7	145.3	36.4	140.8	37.6	136.3	38.8	129.7	40.8				
AQVC 125	1	130.2	29.0	124.1	32.1	121.7	33.4	117.8	35.5	113.3	37.6	110.1	39.1	106.8	40.7	101.8	43.1	96.8	45.5	93.5	47.1
	3	137.5	29.6	131.2	32.6	128.6	34.0	124.6	36.1	119.9	38.2	116.5	39.7	113.1	41.2	107.9	43.7	102.7	46.1	99.3	47.6
	5	144.0	30.1	137.5	33.1	134.9	34.5	130.7	36.6	125.9	38.7	122.4	40.2	118.9	41.7	113.7	44.1	108.4	46.5		
	7	151.1	30.6	144.3	33.7	141.5	35.0	137.2	37.1	132.2	39.3	128.7	40.7	125.1	42.3	119.7	44.7	114.2	47.1		
	9	158.8	31.3	151.6	34.4	148.9	35.7	144.4	37.8	139.2	39.9	135.5	41.4	131.9	42.9	126.6	45.3				
	11	167.3	32.0	159.8	35.1	156.8	36.5	152.1	38.6	146.8	40.7	142.9	42.2	138.9	43.7	132.7	46.0				
	14	180.9	33.4	172.6	36.5	169.3	37.8	163.7	39.8	157.0	41.8	152.1	43.2	147.3	44.6	140.1	46.8				
AQVC 140	1	145.9	32.9	139.1	36.3	136.4	37.8	132.1	40.2	127.0	42.6	123.4	44.3	119.7	46.1	114.1	48.8	108.5	51.6	104.8	53.4
	3	154.1	33.5	147.0	37.0	144.2	38.5	139.6	40.9	134.4	43.3	130.6	45.0	126.8	46.7	120.9	49.5	115.1	52.2	111.3	54.0
	5	161.4	34.1	154.1	37.5	151.2	39.1	146.5	41.4	141.1	43.9	137.2	45.5	133.3	47.3	127.4	50.0	121.5	52.7		
	7	169.4	34.7	161.7	38.2	158.6	39.7	153.8	42.1	148.2	44.5	144.2	46.2	140.2	47.9	134.1	50.6	128.0	53.4		
	9	178.0	35.5	170.0	38.9	166.8	40.4	161.8	42.8	156.0	45.2	151.9	46.9	147.8	48.7	141.9	51.4				
	11	187.6	36.3	179.1	39.8	175.8	41.3	170.5	43.7	164.5	46.1	160.2	47.8	155.7	49.5	148.7	52.1				
	14	202.7	37.9	193.5	41.4	189.7	42.9	183.5	45.2	175.9	47.4	170.5	49.0	165.0	50.6	157.0	53.1				

(*) Compressors only

> Dimensions (mm) - AQVC - R410A - Sizes 85 to 115 <

Bottom view

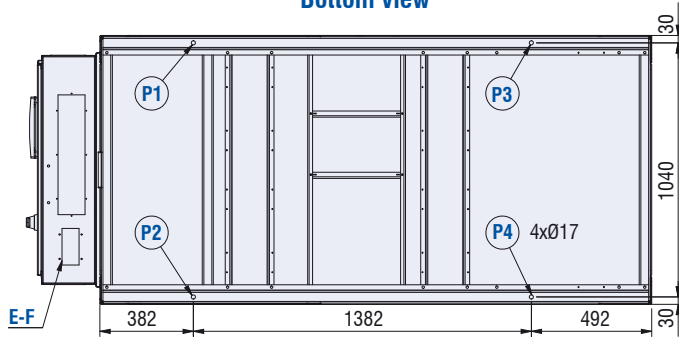

Side view

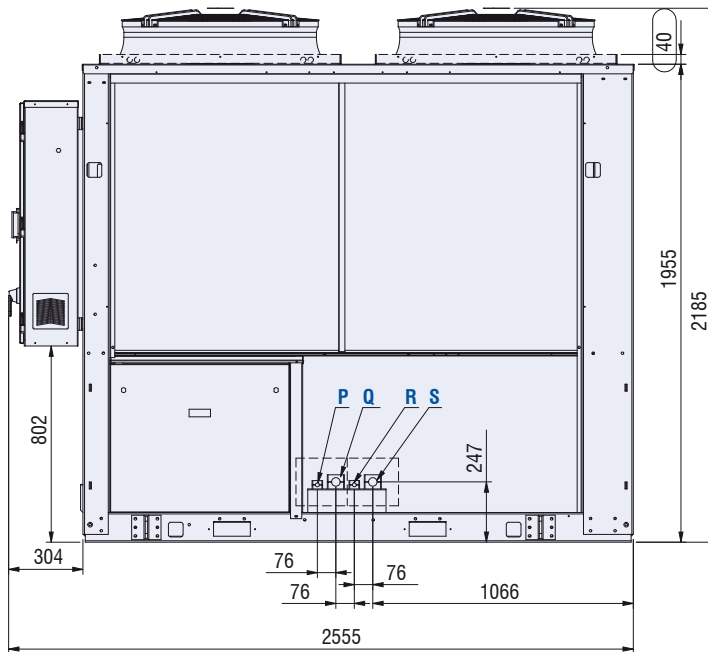

Front view

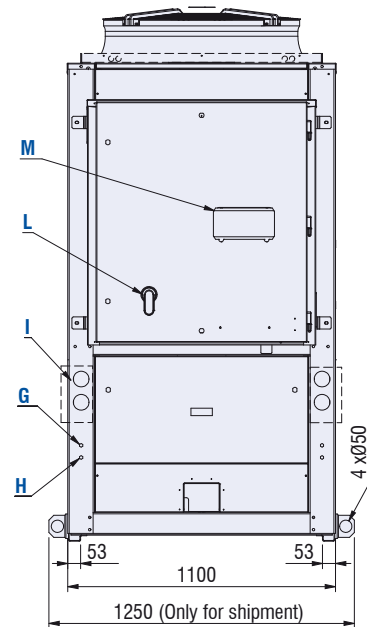

Top view

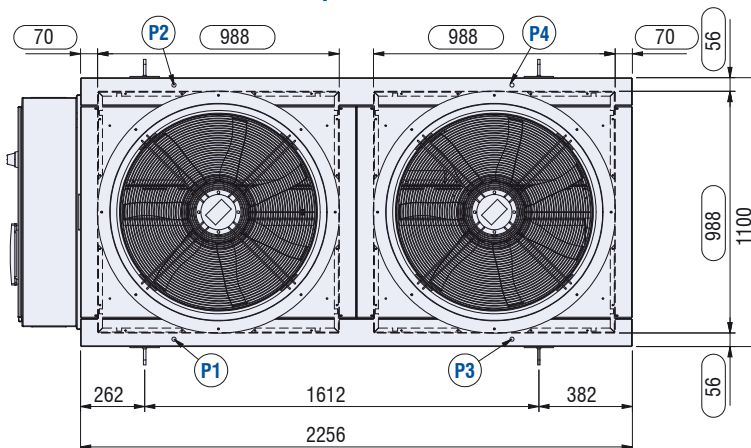

E	Electrical auxiliary lines	L	Main switch	R	Discharge circuit 1
F	Electrical power supply	M	Control keypad / display	S	Suction circuit 1
G	High pressure tap	P	Discharge circuit 2	XXX	Only for HPF fan model
H	Low pressure tap	Q	Suction circuit 2	P1, P2, P3, P4	AVM position
I	Gauge kit (accessory)				



6 sizes with HFC 410A
2 acoustical options

92 to 151 kW

> Dimensions (mm) - AQVC - R410A - Sizes 125 & 140 <

Bottom view

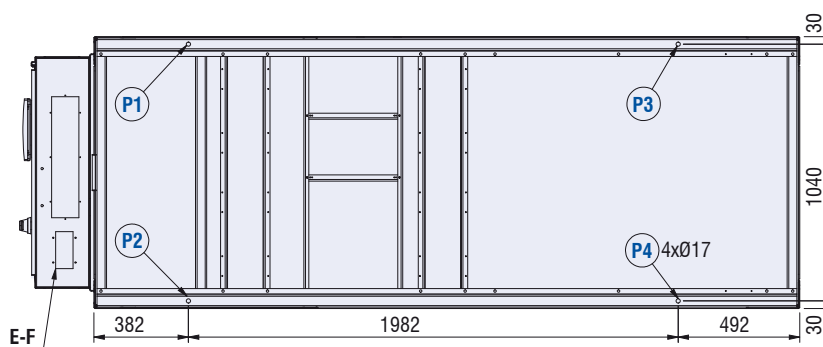

Side view

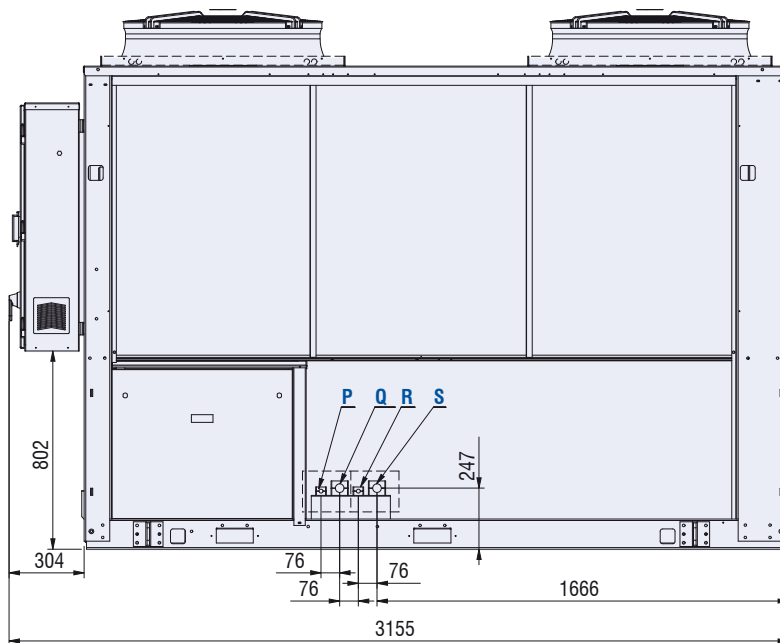

Front view

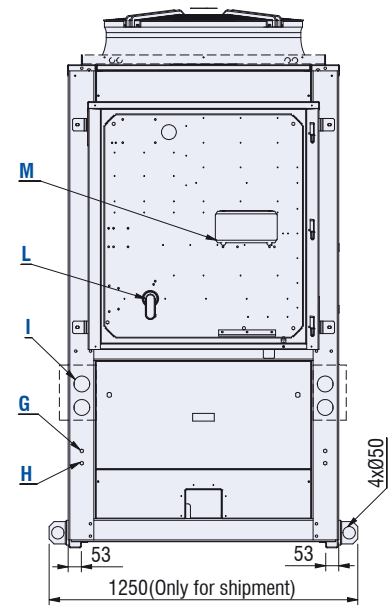

Top view

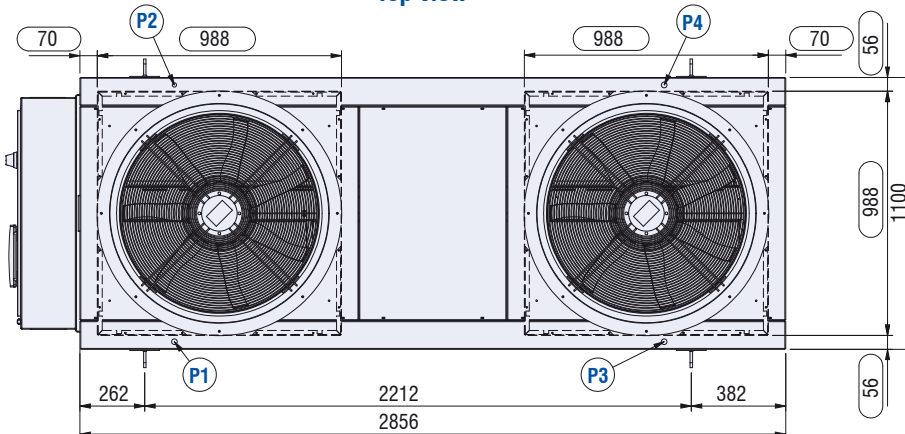

E	Electrical auxiliary lines	L	Main switch	R	Discharge circuit 1
F	Electrical power supply	M	Control keypad / display	S	Suction circuit 1
G	High pressure tap	P	Discharge circuit 2	XXX	Only for HPF fan model
H	Low pressure tap	Q	Suction circuit 2	P1, P2, P3, P4	AVM position
I	Gauge kit (accessory)				

> Unit Clearances (in mm) <

Installation of single units

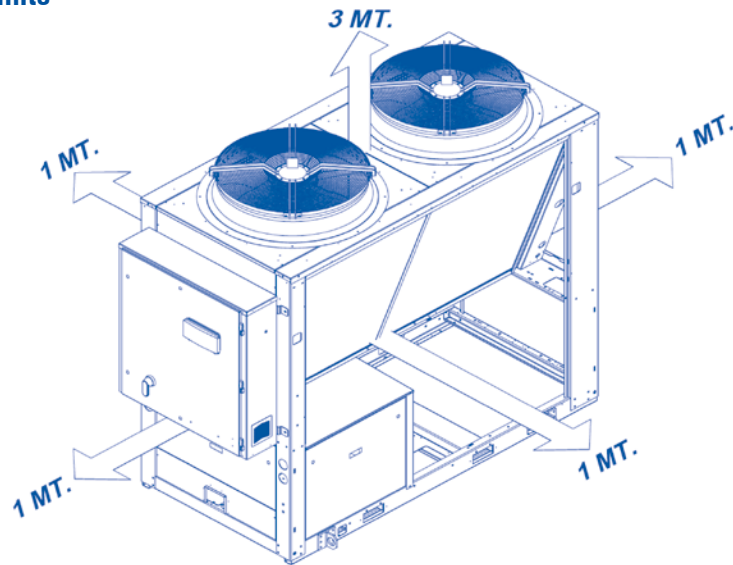

Installation of several units

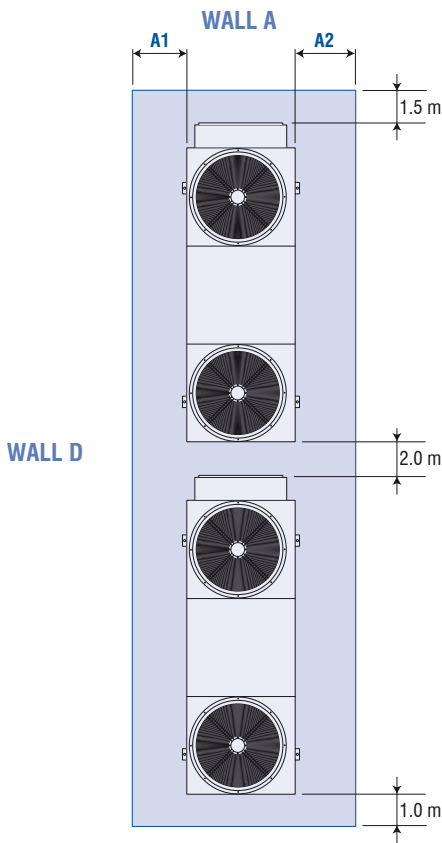

ARRANGEMENT 1

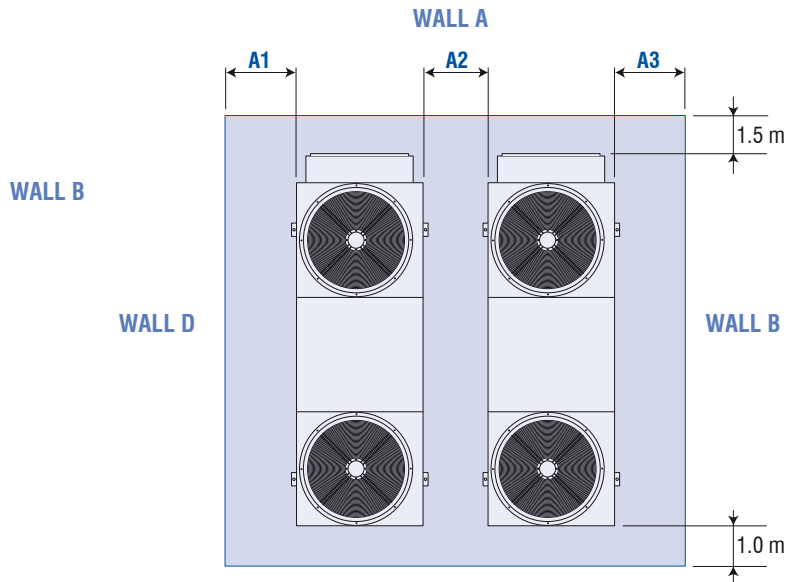

ARRANGEMENT 2

	A and C grille B and D full			A and B full C and D full			A and C full B and D grille			A and B grille C and D full			A and D grille B and C full		
	A1	A2	A3	A1	A2	A3	A1	A2	A3	A1	A2	A3	A1	A2	A3
ARRANGEMENT 1	1000	1000		1000	1000		800	800		1000	800		800	1000	
ARRANGEMENT 2	1000	1500	1000	1000	2000	1000	800	2000	800	1000	1500	800	800	1500	1000

No more than one wall can be higher than the unit.
The area enclosed by the wall must be kept clear of all obstructions that would impede air flow to the unit. Dimensions in mm.