

# KLMQ

Compact air-handling unit with heat recovery

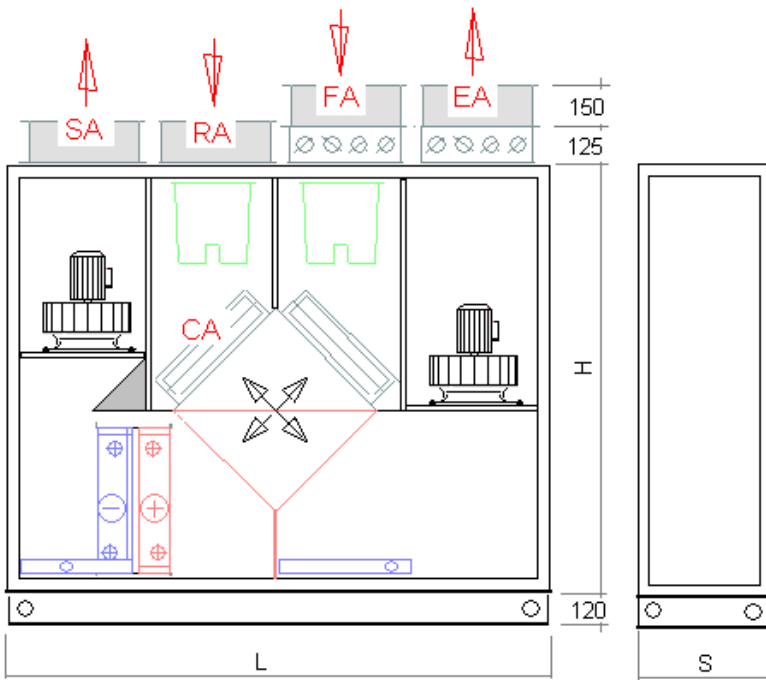

### DIMENSIONS AND WEIGHT



FA = Fresh air  
 CA = Circulation air  
 SA = Supply air  
 RA = Return air  
 EA = Exhaust air

KLMQ	L [mm]	H [mm]	S [mm]	m [kg]
02	1900	1400	550	335
04	2450	1600	650	480
06	2800	1800	800	645
08	3000	1800	1000	805

\* Weight depends on actual configuration of the AHU

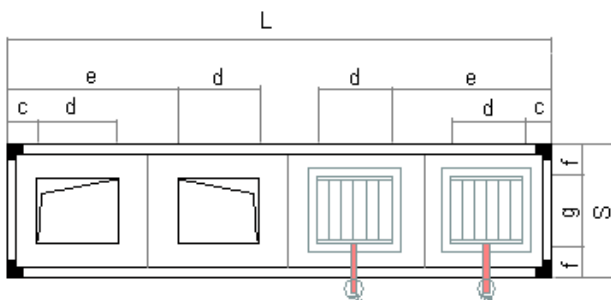

KLMQ	c [mm]	d [mm]	e [mm]	f [mm]	g [mm]
02	32	400	508	27	496
04	43	500	649	30	590
06	30	600	720	27,5	745
08	35	600	820	25	950

### AIRFLOW PERFORMANCE PARAMETERS FOR KLMQ AIR-HANDLING UNITS

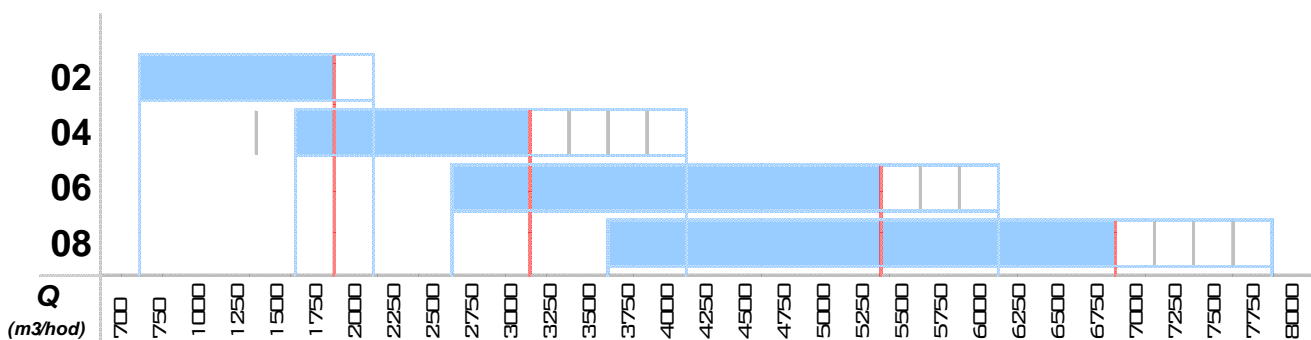

The compact **KLMQ** air-handling units (AHUs) have been designed for use in various applications ranging from industrial to commercial buildings, where the area taken by the air-handling unit is of essence due to confined space and needs to be kept to a minimum. The AHUs provide filtration, heating, cooling, heat recovery and a complete control system. The units are primarily intended for indoor installation inside a ventilation plantroom for air treatment in hygiene applications. The units come in four sizes with airflow capacities ranging from 720m<sup>3</sup>/h to 6,950m<sup>3</sup>/h. During the design process, maximum importance was attached to the practical properties of the unit, reduced size and energy efficiency whilst delivering uncompromised function and performance parameters of the air-handling unit.

### Quality Guarantee

Our air-handling units were awarded quality certificates confirming high quality of the products manufactured in Janka Engineering s.r.o. In 1998, our production facility obtained quality management certificate EN ISO 9001 suggesting high quality of our company.

With regards to safety, our products carry certificate complying with the CE European directive ruling safety of industrial products. As a consequence, we can be issuing conformity certificates for each of our product. This certificate is supplemented by statement confirming appropriateness of our products for employment in buildings. As a recommendation encouraging implementation of our equipment in hygiene applications, a Hygiene Assessment Statement of the air-handling unit was issued by the State Institute of Health in Prague.



### Performance parameters verified by test laboratory

Our factory includes an in-house test laboratory with expert staff equipped with modern measuring instruments for testing of ventilation equipment. All prototypes of proposed new chamber and construction modifications of existing chambers are tested in the laboratory. Thanks to the collected data we can further optimize and elevated performance of our air-handling units. Airflow measurement, air velocity, noise and vibrations can be also measured by portable instruments in-situ on already operational equipment. Measurement certificates can be issued if required.

### Casing construction

Closed galvanized steel profiles connected with plastic corner couplings form the frame of the unit. Casing of the unit is made of stiff, 25mm thick sandwich panels with seating gasket at the perimeter. Inner and outer layer of the panels consists of galvanized metal sheets 0.55mm thick.

Casing characteristics*	
Casing material	Zn 275 g/m <sup>2</sup>
Specific weight of insulation	50 kg/m <sup>3</sup>
Thermal resistance R	1,14 m <sup>2</sup> *K/W
Thermal transfer coefficient k	0,97 W/m <sup>2</sup> *K
Noise attenuation in accordance with DIN 52210	32 dB
Fire rating in accordance with DIN 4102	B2 (B1)
Mechanical stability rate	2A
Tightness of casing in accordance with EN 1886	3A (A)
Thermal bridges factor	TB2

\* Presented data apply to standard polyurethane foam insulation  
Note: the values have been specified in compliance with the Czech code ČSN EN 1886

The panels are lagged with polyurethane foam insulation manufactured in an environmentally friendly way without any release of CFC substances during the production process. Thanks to the use of polyurethane foam, the casing panels are extraordinary stiff and have very good thermal properties comparable with casing panels lagged with 50mm thick mineral wool insulation. On request, the units can be delivered with casing panels lagged with mineral wool insulation and enhanced metal sheet thickness of 0.8mm. All internal baffles inside the unit are provided with thermal insulation lagging as well.

Casing panels are fixed with screws to the steel frame. The seating areas of the panels include rubber gaskets.

### Access to chambers

An easy access to the filtration and fan blocks is provided through access doors located on the service side of the unit. The doors are hinged on plastic hinges and equipped with reliable locks making sure airtight closing of the chambers. The other panels forming unit's casing are fixed and fastened onto the frame with screws.

### Condensate drainage

It comes to condensate formation during operation of the KLMQ air-handling unit in some of the chambers. The condensate is to be drained out. The chambers with condensate occurrence are those including chilled water coils, direct expansion coils and plate heat recovery exchanger. These chambers are equipped with condensate pan with connection spigot. A siphon has to be installed on the connection spigot to prevent dust suction into the chamber through the drainage pipe and to make sure the condensate water is drained out properly. Standard delivery of the air-handling unit includes U-shaped siphons with shut-off ball. Only one connection spigot can connect to the siphon. The siphon and condensate drainage pipes at outdoor installed units should be provided with anti-freeze protection by electrical heating traces.

### Clearance areas around the units

Sufficient clear area must be provided around the AHU for maintenance and servicing works. No clear area is required at the rear side of the AHU. Clear area at the service side of the AHU has to be provided as presented in the table below.

Clearance for repair or replacement of major components:	
Fan section	AHU's width + 200 mm
Hot water coils	AHU's width + 200 mm
Chilled water and DX coils	AHU's width + 200 mm
AHU without any coils	600 mm

### Transport and handling

During transport and handling, the transport modules and chambers can be lifted only suspended at the bottom side. While lifting by crane, it is necessary to use lifting belts placed under the unit. In case of lifting larger modules, it is necessary to keep the lifting belts clear off the modules with a spreader bar in order to avoid any warping of the module. The spots for lifting are marked-up on the unit's base frame by pictogram showing a crane hook symbol. If unloaded by forklift, it is necessary to support the module / chamber across the whole width otherwise the bottom panels can get broken.

**For more information please refer to the Installation and Operation Guide for the KLMQ air-handling units.**

### CONSTRUCTION OF AIR-HANDLING UNITS - MARKING

#### Equipment delivery - base frame

Typically, the AHUs are delivered assembled forming one transport unit. The KLMQ AHUs are mounted on a 120mm high base frame made of galvanized C steel sections with 2mm thick wall. There are cutouts Ø50mm provided in the base frame for handling and holes Ø11mm for fixing the AHUs to concrete plinth. Adjustable legs can be delivered as optional accessory on customer's request.

Standard delivery includes flexible flanges for connection to the ventilation ductwork and following items: airtight dampers for airflow control, bag filters rate G3, G4 and/or F5 on the supply and exhaust side.

An integral part of the KLMQ AHUs is highly efficient plate heat recovery exchanger with control, by-pass and mixing dampers. Drive shafts of the dampers extend beyond the AHU's casing on the service side allowing for easy installation of motor actuators.

Depending on the actual requirements on AHU's performance, it can be equipped with two versions of heating and cooling system - electrical heater or hot water coils; chilled water or direct expansion (DX) cooling.

#### Marking

Each function feature of the AHU has got its unique identification marking / code (see TAB).

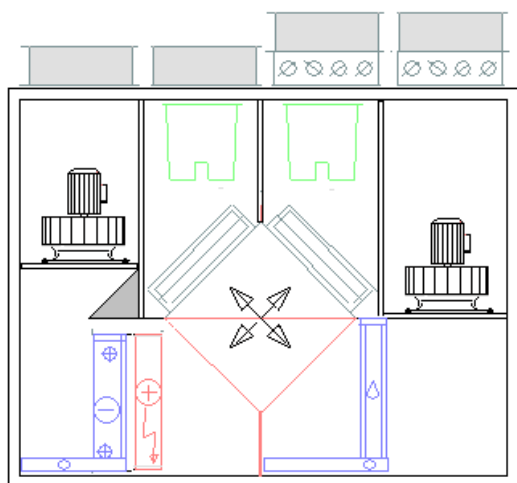

### Type code marking of KLMQ units

KLMQ	Without droplet eliminator	With droplet eliminator	Heating	Cooling
02	200	200 - E	-	-
	212	212 - E	water	water
	242	242 - E	electrical	water
	213	213 - E	water	DX
	243	243 - E	electrical	DX
	210	210 - E	water	-
	202	202 - E	-	water
	240	240 - E	electrical	-
	203	203 - E	-	DX
04	400	400 - E	-	-
	412	412 - E	water	water
	442	442 - E	electrical	water
	413	413 - E	water	DX
	443	443 - E	electrical	DX
	410	410 - E	water	-
	402	402 - E	-	water
	440	440 - E	electrical	-
	403	403 - E	-	DX
06	600	600 - E	-	-
	612	612 - E	water	water
	642	642 - E	electrical	water
	613	613 - E	water	DX
	643	643 - E	electrical	DX
	610	610 - E	water	-
	602	602 - E	-	water
	640	640 - E	electrical	-
	603	603 - E	-	DX
08	800	800 - E	-	-
	812	812 - E	water	water
	842	842 - E	electrical	water
	813	813 - E	water	DX
	843	843 - E	electrical	DX
	810	810 - E	water	-
	802	802 - E	-	water
	840	840 - E	electrical	-
	803	803 - E	-	DX

Marking code example:

#### **KLMQ 08 - 842 - E**

Module includes electrical heater, chilled water coil and droplet eliminator only behind the plate heat recovery exchanger, right-hand side version.

## TECHNICAL SPECIFICATION

### Fans

The fan section of the AHU has been designed to facilitate the air transport. High performance plug fans with low dynamic pressure are used in the AHUs. Since the plug fans do not need to be placed in spiral casing nor need any V-belt drive, cleaning of this section is very straightforward. The fan is connected to the electromotor by a shaft using Taper Lock system.

The impeller is dynamically and statically balanced in the factory and installed on anti-vibration mounts.

Three-phase induction motors 400V/50Hz connected direct by shaft with the impeller provide drive for the fans. Motors are equipped with thermistors as part of standard delivery. Motors' speed must always be controlled by frequency modulators to control and set-up the required airflow.

Bushings for incoming power cables are places on the other side of the AHU.

### AHU's delivery includes as standard

- Electromotor
- Fan with plug fitted to suction base
- Lockable doors
- Frequency modulator
- Service double-layer sight glass

### Optional accessories

- Lighting of the chamber with switch installed on the outer surface of the AHU
- Pressure gauges (fluid manometer or differential pressure gauge)

### Performance characteristics

Type: medium-pressure plug fan

Operation temperature: -20°C / +40°C

Thermal protection: PTC - thermistor

Possibility of control by frequency modulator: YES

Supply voltage:  $U = \sim 3 \times 400V$ ,  $f=50Hz$  ( $\sim 1 \times 230V$ )\*

KLMQ	Q [m3/hod]	Electromotor output [kW]	
		Supply*	Extract*
02	750	0,75	0,75
	1200	0,75	0,75
	1810	0,75	0,75
04	1700	0,75	0,75
	2600	1,1	0,75
	3150	1,5	1,1
06	3000	1,1	1,1
	4200	2,2	1,5
	5260	3	2,2
08	4800	1,5	1,1
	5600	2,2	1,5
	6950	3	2,2

\* The electromotor output values shown in the table correspond to external pressure of max. 250Pa

Electromotor output $P_m$ [kW]	0,75	1,1	1,5	2,2	3	4	5,5
Electromotor nominal current $I_n$ [A]	1,7	2,5	3,5	4,5	6,4	7,8/ 8,2	10,4

KLMQ	Fan			Electromotor output [kW]							
	GR	22	C	0,75	1,1						
02	GR	22	C	0,75	1,1						
	GR	25	C	0,75	1,1						
04	GR	28	C	0,75	1,1	1,5	2,2				
	GR	31	C		1,1	1,5	2,2	3			
06	GR	35	C		1,1	1,5	2,2	3			
	GR	40	C		1,1	1,5	2,2	3	4		
08	GR	40	C		1,1	1,5	2,2	3	4		
	GR	45	C		1,1	1,5	2,2	3	4	5,5	

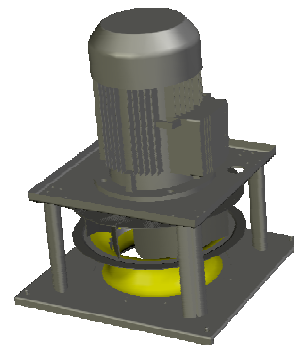

## Heating coils

The heating coils provide heating of the air. Hot water is used as heating medium for the coils. The coils have aluminum fins and copper pipes. A wide range of one, two or three row heating coils with optimized spacing of the fins and number of water flow paths is available for each AHU's size. The maximum temperature of the hot water is 110°C; the maximum operation pressure is 1.6MPa.

All heating coils are tested under test pressure of 3MPa (pressure imposed by dry air). Heating coil connection sockets are capped off with plastic plugs during transport.

### Heating coils delivery includes as standard

- Coils comprising of copper tubes and aluminum fins
- Male threaded steel connection spigots on supply and return side
- Manual bleed-off fitting at top side of the coil

### Optional accessories

- Anti-freeze protection capillary sensor (not fitted)
- Threaded flange and weld counter-flange (not fitted)

### Design recommendations

- Counter flow arrangement of the coil connection to the hydronic hot water system must be provided. Pressure loss of the coils on the water side varies from approximately 1 to 10kPa\*
- Attention must be paid to anti-freeze protection of the coil
- Air temperature behind the coil must not exceed 40°C due to protection of the motor against overheating

KLMQ	Size of hot water coil connection spigots – male threaded G(“)		
	A 1 row	D 2 rows	E 2 rows
02	1/2	1/2	1/2
04	1/2	3/4	3/4
06	3/4	1	1
08	3/4	1 1/4	1 1/4

## Electrical heaters

The heating section comprises electrical heating rods used for heating of the air. The rods are arranged inside of the heating module to form several independent sections. Heating capacity of the heater is controlled by gradual switching-on of the individual sections or alternatively by thyristor-based control achieving step-less heating capacity control.

Power supply cables to the heating rod sections are terminated at clamp box together with the safety thermostat clamps inside the module. Each heating rod section is connected to the power supply 3x400V/50Hz independently. The safety and emergency thermostats are wired as switch-off contacts.

### Delivery includes

- Two safety bimetal thermostat as overheating protection with switch-off setpoint 50°C (wired in series)
- Two emergency capillary thermostats with setpoint 50°C with manual reset (wired in series)

### Optional accessories

- Assembly of the electrical heater can follow customer's requirements on the heating capacity to be provided.

### Design recommendations

- Minimum airflow velocity through the electrical heater is 1.5m/s
- Control/protection systems must make sure that operation of the electrical heater is stopped in case the airflow in the AHU is insufficient or none and the after-run of fans must be provided for at least three minutes after the electrical heater is switched-off.
- The electrical heaters are subject of regular mandatory checks in accordance with the Czech code ČSN 35 1500

### Performance characteristics

Heating capacity: 6 – 54 kW (see TAB)

Number of heating sections: 1 – 5 (see TAB)

KLMQ	TYPE	A	D	E
	Q [m3/hod]	Output temperature [°C]**		
02	750	17,1	32,3	41,2
	1200	12,7	26,6	34,4
	1810	11	21,8	28,6
04	1700	17,4	31,7	44,7
	2600	12,4	26,5	38,5
	3150	13,1	24,2	35,6
06	3000	20,3	33,9	40,8
	4200	17,9	29,7	36,0
	5260	16,4	27,1	32,8
08	4800	21,5	35,1	43
	5600	19,2	31,2	38,2
	6950	17,7	28,6	35,1

\*For exact water flow calculation, pressure loss of the coils (kPa) and sizes of the connection spigots please contact our business department.

\*\*Output temperature of the supply air (see TAB) has been calculated for 100% airflow through the plate heat recovery exchanger at -15°C outdoor temperature and 90% relative humidity. Hot water heat coils are designed for water temperature gradient of 80/60°C.

KLMQ	Heating capacity [kW] / number of sections			
02	6/1	12/2	18/3	
04	9/1	18/2	27/3	
06	18/2	27/3	36/4	45/5
08	27/3	36/4	45/5	54/3

### Chilled water coils and DX (direct expansion coils)

The cooling section comprises chilled water coils providing cooling of the air. Chilled water or alternatively glycol anti-freeze mixture is used as heat carrying medium. In case the DX cooling system is implemented, the cooling section comprises evaporator providing cooling of the air through direct evaporation of the refrigerant inside the evaporator. The evaporator is always connected to the condenser unit via a dedicated refrigerant circuit.

A wide range of three or four row chilled water coils with optimized spacing of fins and number of water flow paths is available for each AHU's size. The minimum chilled water temperature is not limited, though the chilled water must not freeze-up. The maximum operation pressure of the chilled water coils is 1.6MPa.

Chilled water coil's in and out connection sockets are made of steel, provided with male thread and capped off with plastic plugs during transport.

DX cooling is provided by a range of three, four or six row evaporators consisting of one to four refrigerant circuits with optimized spacing of fins. Evaporators are suitable for use with R407C and R410A refrigerants. The maximum operation pressure of the refrigerant is 250kPa. In and out sockets on the evaporator are made of copper, ready for soldering connection.

The chilled water coils comprise of aluminum fins and copper tubes and are tested under test pressure of 3MPa (pressure imposed by dry air).

Chilled water coil chamber has aluminum drop pan for condensate collection with a socket of outer diameter of 30mm for siphon connection.

#### Chiller water and DX coils delivery includes as standard

- Chilled water coil with aluminum fins and copper tubes
- Manual bleed-off fitting at top side of the coil
- Aluminum drop pan for condensate collection, siphon

#### Optional accessories

- Stainless steel drop pan for condensate collection
- Hydrophilous fins' treatment
- Threaded flange and weld counter-flange (not fitted) - only for chilled water coils

#### Design recommendations

- Counter flow arrangement of the coil connection to the hydronic hot water system must be provided.
- Pressure loss of the coils on the water side varies from approximately 1-30kPa\*
- In case of an anti-freeze mixture is used this must be compatible with copper (Friterm, ....)
- Two circuit coils are recommended to be specified for cooling capacity above 40kW
- Connection pipes between evaporator and condenser unit must include following fittings: expansion valve, automatic shut-off solenoid valve, filter-dehydrator, sight glass and copper piping provided with vapor-tight insulation.
- Condensate drain-out pipes must be connected through siphon

### Performance characteristics

Cooling medium: water (water+glycol)\*

Suitable refrigerator for evaporator: R407C, R410A\*

Spacing of fins: 2.12; 2.54; 3.17; 4.23mm

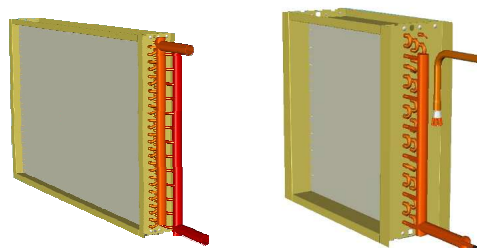

KLMQ	TYPE	O	P	R	S	T
	Q [m <sup>3</sup> /hod]	Output temperature [°C]**				
02	750	19,8	18,8	16,8	17,1	16,7
	1200	21,5	20,7	18,9	18,0	16,9
	1810	22,8	22,2	20,6	19,8	17,5
04	1700	21,1	19,3	17,7	17,7	16,6
	2600	22,5	20,9	19,4	18,2	17,2
	3150	23,1	21,6	20,2	19,0	16,8
06	3000	20,8	19,4	17,4	17,2	16,8
	4200	22,0	20,7	18,8	17,2	17,1
	5260	22,7	21,6	19,8	18,3	17,6
08	4800	21,5	19,5	18,5	18,3	16,7
	5600	22,0	20,1	19,2	17,8	17,0
	6950	22,8	20,9	20,1	18,8	17,1

\* For exact water flow calculation, pressure loss of the coils (kPa) and sizes of the connection spigots and detailed technical specifications of DX evaporators please contact our business department.

\*\*Output temperature of the supply air (see TAB) has been calculated for 100% airflow through the plate heat recovery exchanger at +32°C outdoor temperature and 40% relative humidity and water temperature gradient of 6/12°C

KLMQ	Size of chilled water coils' connection spigots – male threaded G(“)				
	typ O	typ P	typ R	typ S	typ T
02	1/2	1/2	1/2	1/2	1/2
04	1/2	1/2	3/4	3/4	3/4
06	1	1	1	1	1
08	1	1	1	1	1 1/4

### Plate heat recovery exchanger

The heat recovery section comprises plate heat exchanger used for heat recovery from the extracted air. The actual heat recovery exchanger is a cube consisting of aluminum plates (lamellas) arranged in such a way that the fresh air and extract air is passing through the exchanger between the lamellas in two cross directions, mutually separated. In winter season, the extract air passing through the exchanger gives off the heat energy to the lamellas that heat-up the cold outdoor fresh air passing through the exchanger separately in cross direction. The plate heat recovery exchanger can also be used for mixing of return and supply air. Energy efficiency of the heat recovery depends on temperature and humidity of the air and reaches up to 60%.

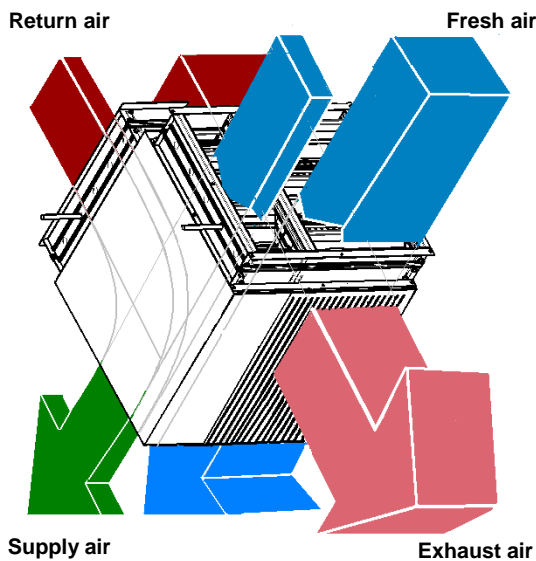

The exchanger cube assembly is installed in heat recovery chamber and sealed with silicon-free putty. Exchanger cube assembly cannot be taken out from the chamber. The exchanger is featured with fresh air by-pass on the intake side and integrated mixing damper, which allows for air re-circulation with partial air re-heat. The by-pass damper is also used for protection against freezing of condensate water on the exchanger inner surface, alternatively also for achieving free cooling. Drive shaft of damper extends beyond the casing on the AHU's service side. Aluminum drop pan collecting the condensate is installed on the extract air side of the exchanger. The drip pan slopes towards the AHU's service side and is provided with siphon connection.

#### Plate heat recovery exchanger delivery includes as standard

- Aluminum cube of the exchanger
- Aluminum drop pan for condensate collection, siphon
- By-pass on the fresh air side
- Integrated mixing damper

#### Optional accessories

- Motor actuator for by-pass and mixing damper
- Plastic droplet eliminator

#### Design recommendations

- Condensate drain-out pipe must be connected to siphon
- With respect to the noise generated and to make sure optimal performance of the equipment, the maximum

airflow limits as presented in the table below are to be observed when the AHU operates under use of the by-pass and mixing damper (see TAB)

KLMQ	Q <sub>max</sub> air mixing
	[m <sup>3</sup> /hod]
02	1530
04	1905
06	3360
08	3360

### Filters

The filtration section is used for air filtration. Filters' specification complies with the codes EN 779 / ASHRAE / EUROVENT. Bag filters of filtration rating G3, G4 and F5 with bag length 360mm are available. Filters are installed in the AHU on the fresh air and exhaust air side.

#### Filters' delivery includes as standard

- Frame with sealing gasket for fixing the filters
- Inspection doors with sight glass and lock

#### Optional accessories

- Fluid pressure gauge for visual check of filter clogging

#### Design recommendations

- Maximum recommended pressure loss on the filters is 250 Pa
- Filters arrangement inside the filtration chamber (see TAB)



		AxBx360	
02	402x409		
04	592x592		
06	287x592		
	402x592		
08	287x592		
	592x592		

## AHU DESCRIPTION

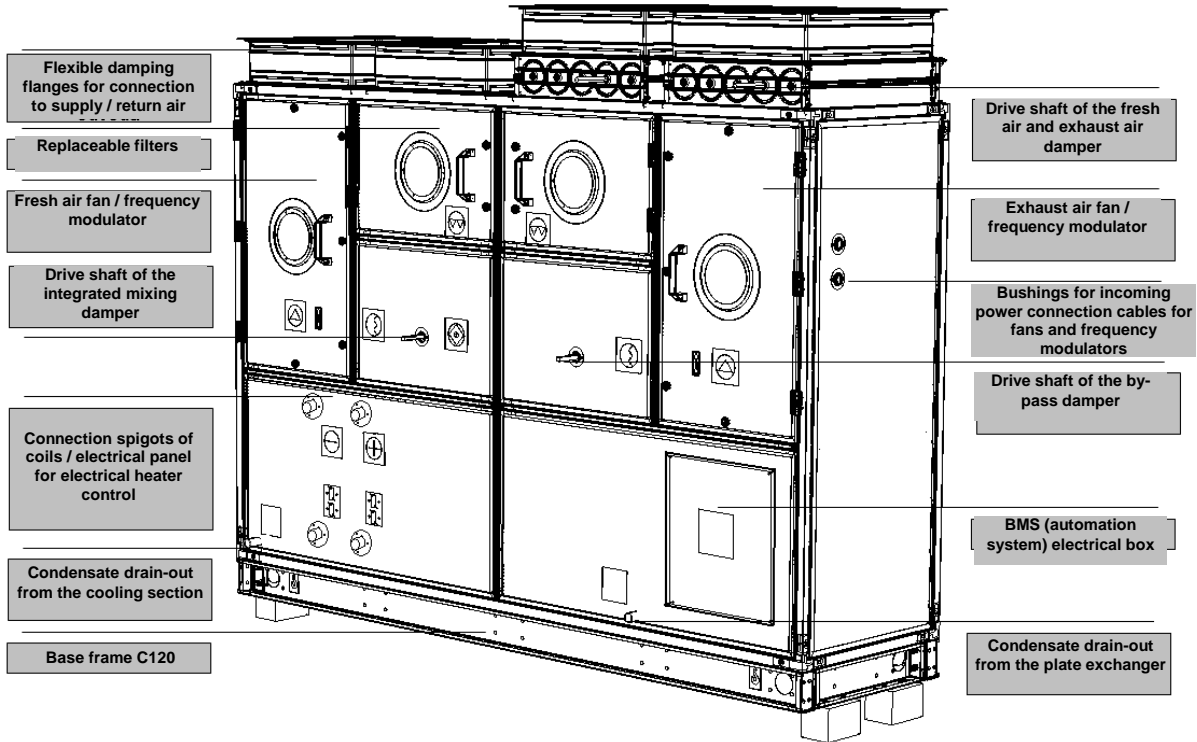

### Dimensions of connection flexible flanges

KLMQ	Intake / exhaust		
	g	d	h
	[mm]	[mm]	[mm]
02	496	400	150
04	590	500	150
06	745	600	150
08	950	600	150

### Torque moments for dampers' motor drives

KLMQ	Damper		
	Intake/ exhaust	Plate exchanger	Integrated mixing
	[Nm]	[Nm]	[Nm]
02	4	4	4
04	4	4	4
06	8	8	4
08	8	8	4

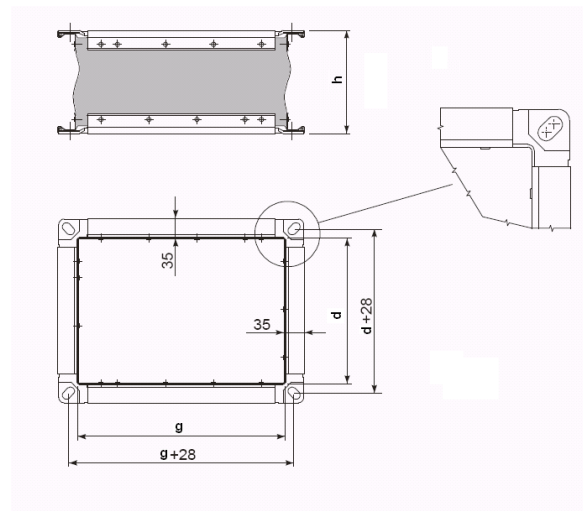

## AHU's ACCESSORIES

### Sight glass

Provides possibility of visual check of filters' clogging and fans' operation. Optionally can be installed on filtration and fan chambers on the intake / exhaust air sides.



interface RS-485/Modbus and PI regulator. Basic version has got protection rating of IP20.

### Colors available

Exterior surface is factory painted RAL 9002. Frame profiles are factory painted RAL 3020 (red).

### Adjustable legs



For aligning and leveling the AHU if installed on an uneven substructure. Legs are fixed to the base frame C120. Clear height of the AHU above the base frame can be adjusted in the range from min.

+80mm to max. +150mm.

### Anti-freeze protection thermostat

Monitors air temperature at the heating coil and protects the heating coil from damage caused by freezing. The thermostat has tiny variation of trigger temperature, can be set manually or automatically.



### Actuator motors

Actuator motor drives open and close the dampers. Position of the damper is monitored. DC voltage 0...10V is used as the control signal. The actuator motor can be energized by either AC voltage 230V or AC/DC voltage 24V.



### Differential pressure switch

Monitors total or differential air pressure. Suitable for detection of clogged filters, ice formation on chilled water coils or monitoring of fans' operation.



### Automation system

The AHU's operation control is easy thanks to the user-friendly control panel installed. The control system monitors function of all the important components of the AHU such as fans, heating/coiling coils, temperature values, airflow, operation time and other internal and external functions. Alarm messages of clogged filters and faults appear on the display. Delivery of all KLMQ AHUs includes relevant wiring, regulator and control panel.

### Frequency modulators



Provide stepless control of the fan speed. Featured by self-explanatory menu, compact dimensions and built-in adjustable cooling. Basic version is equipped with communication

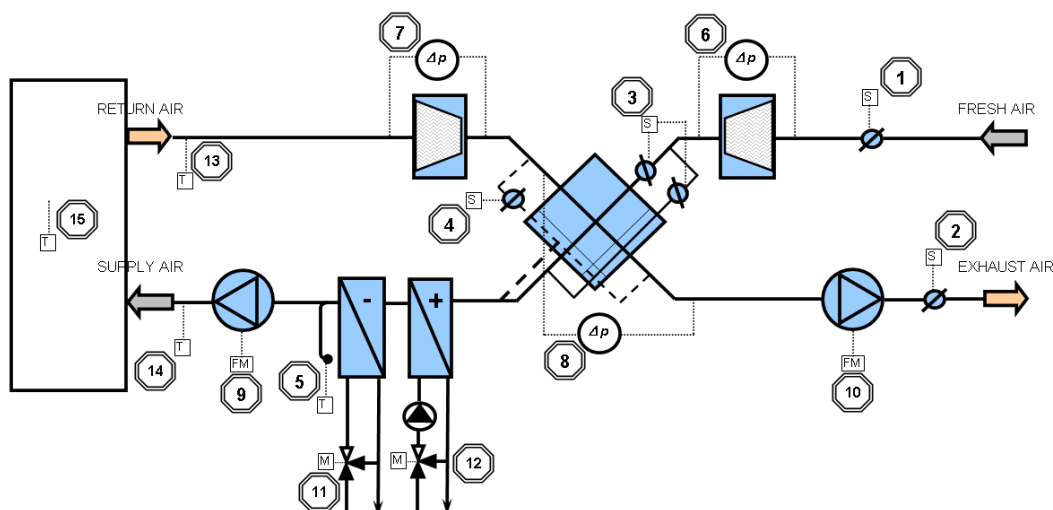

### Typical configurations of the KLMQ air-handling units

Supply and exhaust configuration with heating and cooling

- Fresh air damper
- Pocket filter G3, G4, F5
- Circulation damper integrated to plate exchanger
- Water heater
- Water cooler/direct evaporator
- Plug fan
- Supply air outlet

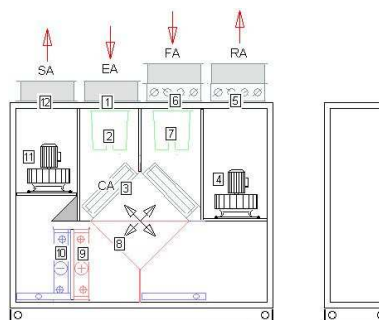

Supply and exhaust configuration, type x00

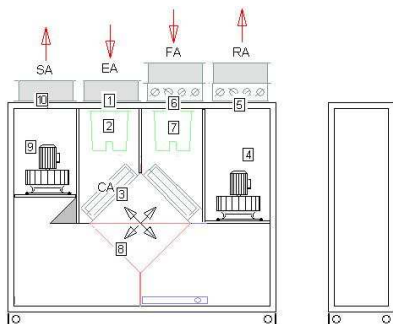

Supply and exhaust configuration with droplet eliminator, type x00-E

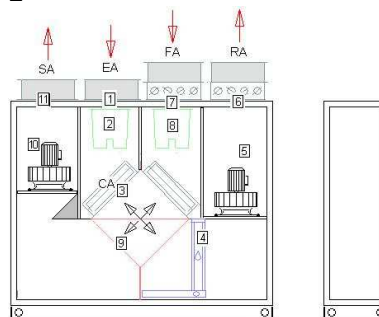

Supply and exhaust configuration, heating and cooling, type x12, x13

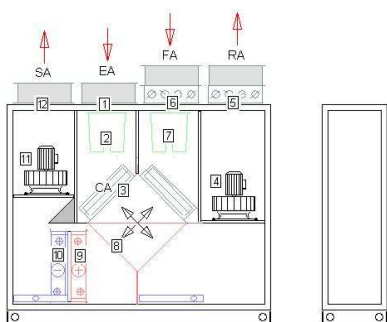

Supply and exhaust configuration, heating and cooling and drop eliminator, type x12-E, x13-E

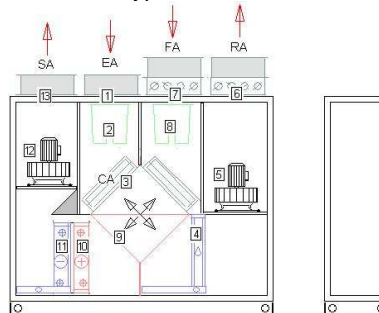

Supply and exhaust configuration with electrical heater and cooling, type x42, x43

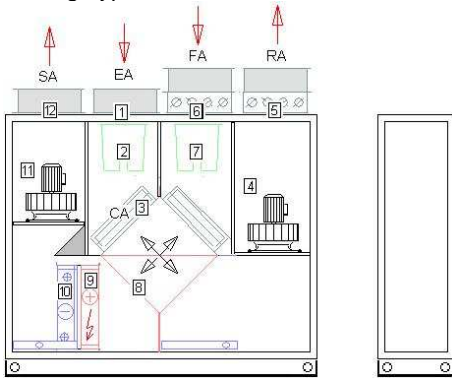

Supply and exhaust configuration, electrical heater and cooling and droplet eliminator, type x42-E, x43-E

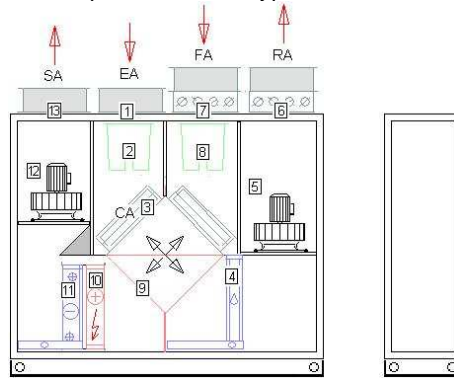

Supply and exhaust configuration with heating type x10

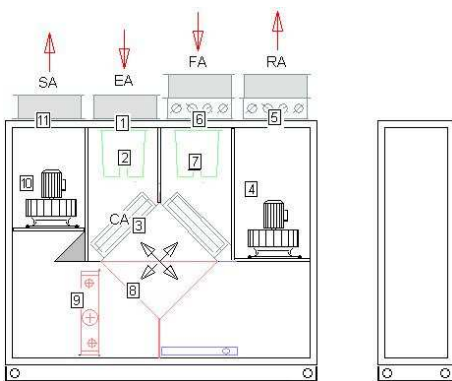

Supply and exhaust configuration with heating and droplet eliminator type x10-E

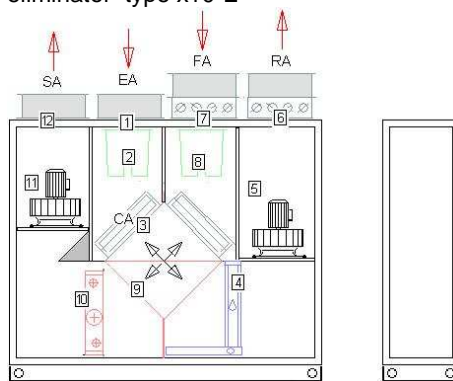

Supply and exhaust configuration with cooling type x02, x03

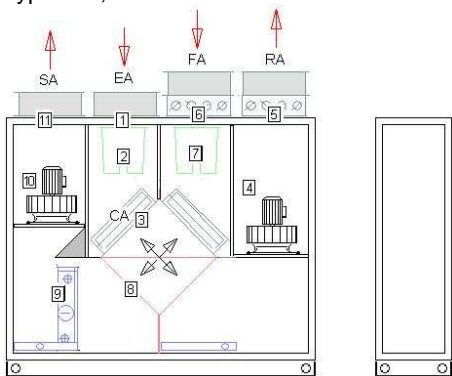

Supply and exhaust configuration with cooling and droplet eliminator type x02-E, x03-E

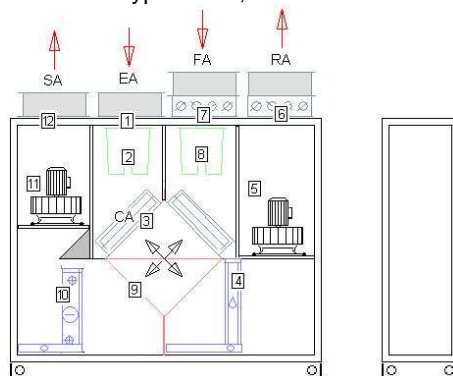

Supply and exhaust configuration with electrical heater type x40

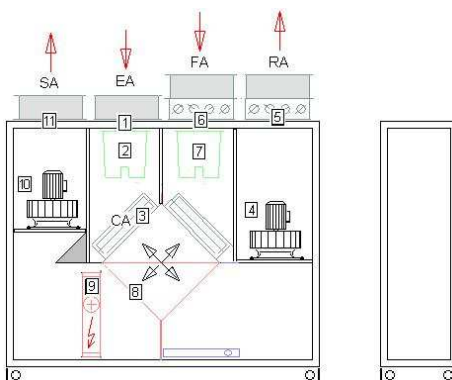

Supply and exhaust configuration with electrical heater and droplet eliminator type x40-E

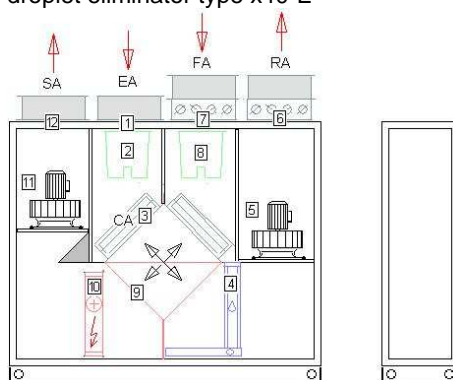



JANKA ENGINEERING s.r.o.

In case of any query with regards to the design, installation and operation of the air-handling unit or if you require copies of certificates of the product or manufacturer, please refer to our web side [WWW.JANKA.CZ](http://WWW.JANKA.CZ) or contact our business department:

JANKA ENGINEERING s.r.o., Vrážská 143, 153 01 Praha 5 – Radotín  
Tel.: 00420 251 088 111, Fax: 00420 251 088 155